



PROSENSE PQ Series Gas Detectors Installation and User Manual



Prosense Teknoloji San. Ltd. Şti.
Yukarı Mah. Harman sok. No:42 Kartal İstanbul
Tel: (90) 216 306 77 88 Faks: (90)216 473 81 29
www.prosense.com.tr

WARNING!
READ THIS INSTRUCTION FIRST!

This manual must be carefully read by all persons who have or will have the responsibility for installing, using or servicing this product.

Like any equipment, this product will perform as designed only if installed, used and serviced in accordance with the manufacturer's instructions. Otherwise, it could fail to perform as designed and persons who rely on this product for their safety could suffer severe personal injury or death.

The warranties made by Prosense with respect to this product are voided if the product is not installed, used and serviced in accordance with the instructions in this user guide. Please protect yourself and other by following them.

Important Remark

The detector has been factory-tested before delivery. The commissioning has to be terminated by a function test of the complete gas detection system.



DO NOT REMOVE COVER WHEN ENERGISED!
ELECTROSTATIC HAZARD - CLEAN ONLY WITH A DAMP CLOTH!

Contents

- Safety Information..... 5
 - Strictly follow the Instructions for Use..... 5
 - Maintenance 5
 - Use in areas subject to explosion hazards 5
 - Liability for proper function or damage 5
 - Intended Use 6
- Introduction..... 8
- Detector body..... 11
- Sensor Head..... 12
- Installation..... 12
- Mounting the detector..... 14
- Electrical connections..... 15
- Cabling..... 17
- Detector grounding 18
- Default configuration 19
- Detector Configuration..... 20
 - 4-20 mA output: 20
 - RS485 serial communication output: 20
 - Detector Relay module:..... 21
 - Oxygen detectors: 22
- System Status 23
- Commissioning 24
 - Commissioning PQD 24
 - Commissioning PQN 25
- Detector Settings..... 26
 - Entering the menu:..... 26
 - Menu structure..... 27
 - Alarm Settings 27
 - Configure 29
 - Change date and time 29
 - Change Modbus address 30
 - Change Analogue Output 30
- Display Parameters..... 30
 - Change Language 31
 - Change Zero Suppression 31
 - Change password 31
 - Detector Model 32
- Bump Test..... 32
 - Change Test Interval..... 33
 - Adjust Inhibit warning 33
- Information Menu options 34
 - Display Event Logs 34
 - Display Concentration Trends 34
 - Display Measurements 35
 - Display Transmitter information 35
 - Display Transmitter information 35

Test Menu Options	36
Run Inhibit test	36
Run Display test	37
Run Relay test.....	37
Run Analogue Output test.....	38
Run Bump Test	38
Calibration	40
Set Reference Gas details	41
Set Calibration Cycle.....	42
Zero Calibration	42
Span Calibration	43
Cancel Calibration.....	43
Maintenance	44
Proactive maintenance:.....	44
Operational Life:.....	44
Servicing	44
Battery	44
Sensor replacement:	45
Pellistor sensor replacement:.....	45
Electrochemical sensor:	45
Infrared Sensor:.....	45
Sensor PCB replacement:	46
Sinter replacement:.....	46
Sensor head replacement:	46
Detector Transmitter board replacement:.....	47
PQD Detector Display Module replacement:	47
Detector Relay Module replacement:.....	48
Status Codes:	49
Spare Parts	50
General specification.....	52
SAFETY INSTRUCTIONS FOR HAZARDOUS AREA INSTALLATION	53
Certificate	55
Declaration	58
Warranty statement.....	59

Safety Information

Ensure that this Operating Manual is read and understood **BEFORE** installing / operating / maintaining the equipment. Pay particular attention to Warnings and Cautions. All document Warnings are listed here and repeated where appropriate at the start of the relevant chapter(s) of this Operating Manual. Cautions appear in the sections/sub-sections of the document where they apply.

Strictly follow the Instructions for Use

Any use of the detectors requires full understanding and strict observation of these instructions. The detector is only to be used for purposes specified here.

The cover on Detector must be kept tightly closed until power to the detector is isolated otherwise ignition of a flammable atmosphere can occur. Before removing the cover for maintenance or calibration purposes, ensure the surrounding atmosphere is free of flammable gases or vapours.

Detectors must be protected from extreme vibration and direct sunlight in hot environments as this may cause the temperature of the detector to rise above its specified limits and cause premature failure.

Maintenance

It is recommended to obtain a service contract Prosense to carry out all repairs. Only authentic Prosense spare parts must be used, substitute components may invalidate the certification and warranty of the detector. Maintenance and calibration operations must only be performed by qualified service personnel.

Use in areas subject to explosion hazards

Equipment or components which are used in potentially explosive atmospheres and have been tested and approved according to international or European regulations may be used only under the conditions specified here. Modifications of components or the use of faulty or incomplete parts are not permitted. In case of repairs of equipment or components, the national regulations must be observed.

Liability for proper function or damage

The liability for the proper function of the detector is irrevocably transferred to the owner or operator to the extent that the detector is serviced or repaired by personnel not employed or authorized by Prosense or if the sensing head is used in a manner not conforming to its intended use. Prosense cannot be held responsible for damage caused by non-compliance with the recommendations given above. The warranty and liability provisions of the terms of sale and delivery of Prosense are likewise not modified by the recommendations given above.

Intended Use

The PQ series detectors are intended to be used for stationary, continuous monitoring for combustible gas/air or vapour/air mixtures below the Lower Explosion Limit (LEL) and toxic gas/air mixtures in particule per million (PPM) units. The detectors are marked by the device categories II 2G that can be operated in hazardous areas with potentially explosive atmospheres of zones 1 and 2. The type of protection for gas explosion protection according to device category 2 (zones 1 or 2) is flameproof enclosure and increased safety, "db". The enclosure protection is IP 65.

According to the ATEX Directive 2014/34/EU the detector is an assembly consisting of three components (Sensor Head, enclosure and cable gland), where all these three components are type approved according to ATEX Directive 2014/34/EU and marked by the device category II 2G. Thus this detector is suitable to be operated in hazardous areas with potentially explosive atmospheres of zone 1 and zone 2. The PQ series detector comprises a gas sensor type Ex-proof (protection type flameproof enclosure db type). PQ Series detector for flammable gases performs % 0 to % 100 LEL measurement range; for toxic gases the measurement range would be vary. The measurement range and environmental conditions are written on each detector label.

Hazardous area classifications:

Zone 0: An area classified as Zone 0 will have ignitable concentrations of flammable gases, vapours or liquids either continuously present or present for long periods of time under normal operating conditions

Zone 1: An area classified as Zone 1 is likely to have ignitable concentrations of flammable gases, vapours or liquids present under normal operating conditions. Flameproof (Ex db) detectors are suitable for use in Zone 1.

Zone 2: An area classified as Zone 2 is not likely to have ignitable concentrations of flammable gases, vapours or liquids present under normal operating conditions. Flameproof (Ex db) detectors are suitable for use in Zone 2.

Not to be used in oxygen enriched atmospheres.

PQ series with pelistör sensor for flammable gas detectors are designed to detect gases or vapours in air and not inert or oxygen deficient atmospheres. PQ oxygen detectors can measure in oxygen deficient atmospheres.

In conjunction with the central controllers Prosense detectors with preadjusted alarm thresholds audible and visible alarm devices or automatic countermeasures can be activated before the detected gases or vapours can form dangerous flammable or toxic mixtures with air. Please be alerted in following special conditions may have impact on measuring function due to the nature of measuring method:

1. Very high gas concentrations

The measuring method of PQ series detector based on heat produced by reaction on the oxidation of a flammable gas when pellistor sensor used. There is not enough oxygen in the sensor to perform oxidation process correctly in case of high gas concentrations. Hence the measuring signal decreases at high gas concentrations and even can lead to measuring signal within the measuring range again. In case of high flammable gas concentration, do not reset latching alarms without having ensured a safe condition in the environment via performing necessary checks.

2. Minimum oxygen concentration

The measuring principle of heat of reaction needs a minimum oxygen concentration of 15 % by volume; otherwise the measuring values will be too low because of oxygen deficiency.

3. Long-term gassing with methane at very low temperatures

If the Prosense PQ series flammable gas detectors with pelistör sensor are operated applying with methane at very low temperatures, the measuring signal at long term exposition may decrease after alarm activation and may lead to misinterpretation.

If a gas alarm occurs, necessary actions need to be taken immediately. The decrease of the measuring signal should not mean that the gas concentration has been decreased. We recommend to keep alarms on the associated controllers and not to reset these alarms without performing measurement with an independent gas detector to make sure conditions are safe.

Introduction

The Prosense comprises a gas detector body and a choice of sensors heads for detecting flammable gases, toxic gases and oxygen. The construction of Prosense PQ Series detectors allows it to be used in hazardous area locations; it may also be used in other areas not classified as hazardous.

Prosense PQ Series detectors can be configured with a wide range of different sensors may be used to detect a broader range of target gases. The detector can be configured with optional relay board features three programmable relays for controlling external equipment e.g. alarms, sirens, valves or switches. The detector provides an industry standard 3-wire, 4-20mA output for connection to a dedicated gas detection control system or PLC. It can also provide RS485 serial communication with integrated onboard devices.

PQ Series detectors are available as PQN and PQD names. PQD and PQN are uses same electronics, sensors, sensor heads and firmware. PQD has an integrated screen on detector itself and the cover has window made from glass while PQN has aluminium cover without window as it does not have screen.

PQ Series gas detectors for monitoring a very wide range of toxic and flammable gases and oxygen. PQ series are available as Flameproof (Ex db) detectors suitable for use in Zone 1 or 2 hazardous areas. Please refer to the certification label on the detector junction box to identify the type of certification that relates to the product supplied. Hazardous area definitions are shown in the Hazardous area classifications section on page 6.

Note: if no certification label is fitted to the junction box, the detector is not certified for use in hazardous areas.

PQ Series detector labels are provided in Diagram-1. Prosense PQ series gas detectors may be installed in hazardous area with flammable gases, vapours, and mist, group II, category 2G, maximum superficial permissible temperature 70°C.

Device category 2G, Identification II 2G

Ex db IIC T6 Gb (Tamb = -40 °C ÷ +70 °C) – For explosion protection

(Tamb = -20 °C ÷ +60 °C) – For performance

It means:  (European Community logo for ATEX applications) – group II (potentially explosive atmospheres – surface application – OTHER than mines)

Category 2G (G => Gas) – Zone 1 and Zone 2

Ex db => protection mode: explosion proof enclosure

IIC => define kind of gases

T6 => Temperature class -- Maximum allowable surface temperature.

IP 65 => Mechanical protection degree – protection against solid, dust and liquid.

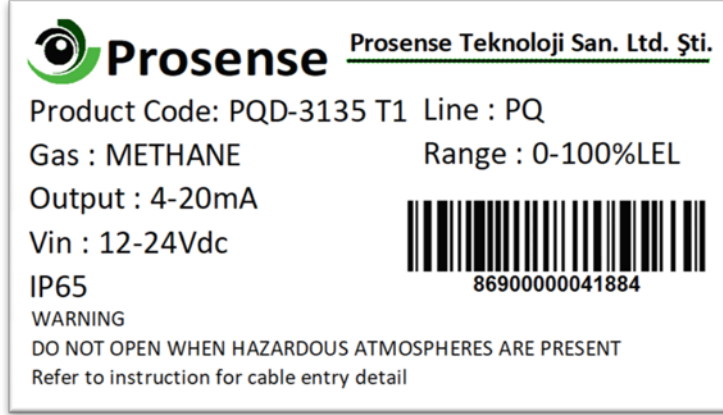

Label A

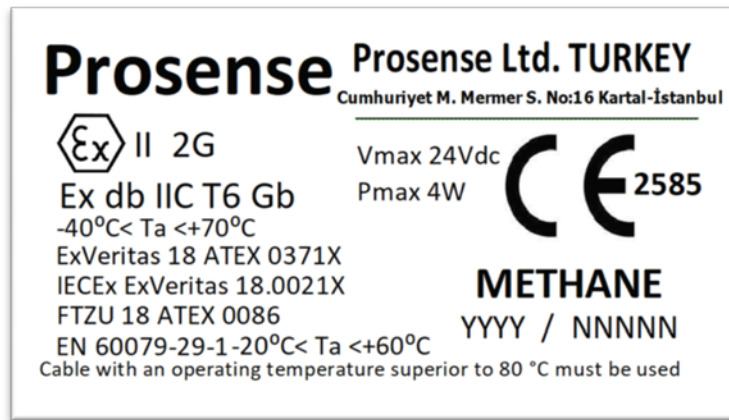

Label B *

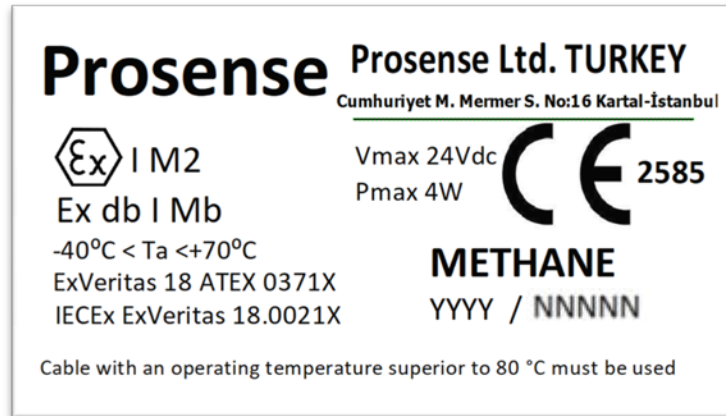

Label C *

Diagram1: PQ Series Detector labels

*

Label A: Product definition

Label B: Product label based on ATEX and IECEx directives

Label C: Group I Product label

XXXX is the four digit NB number issuing current QAN and QAR

YYYY is the manufacturing date

NNNNN is the serial number of the equipment

Prosense PQD detectors comprises of the main parts as shown below:

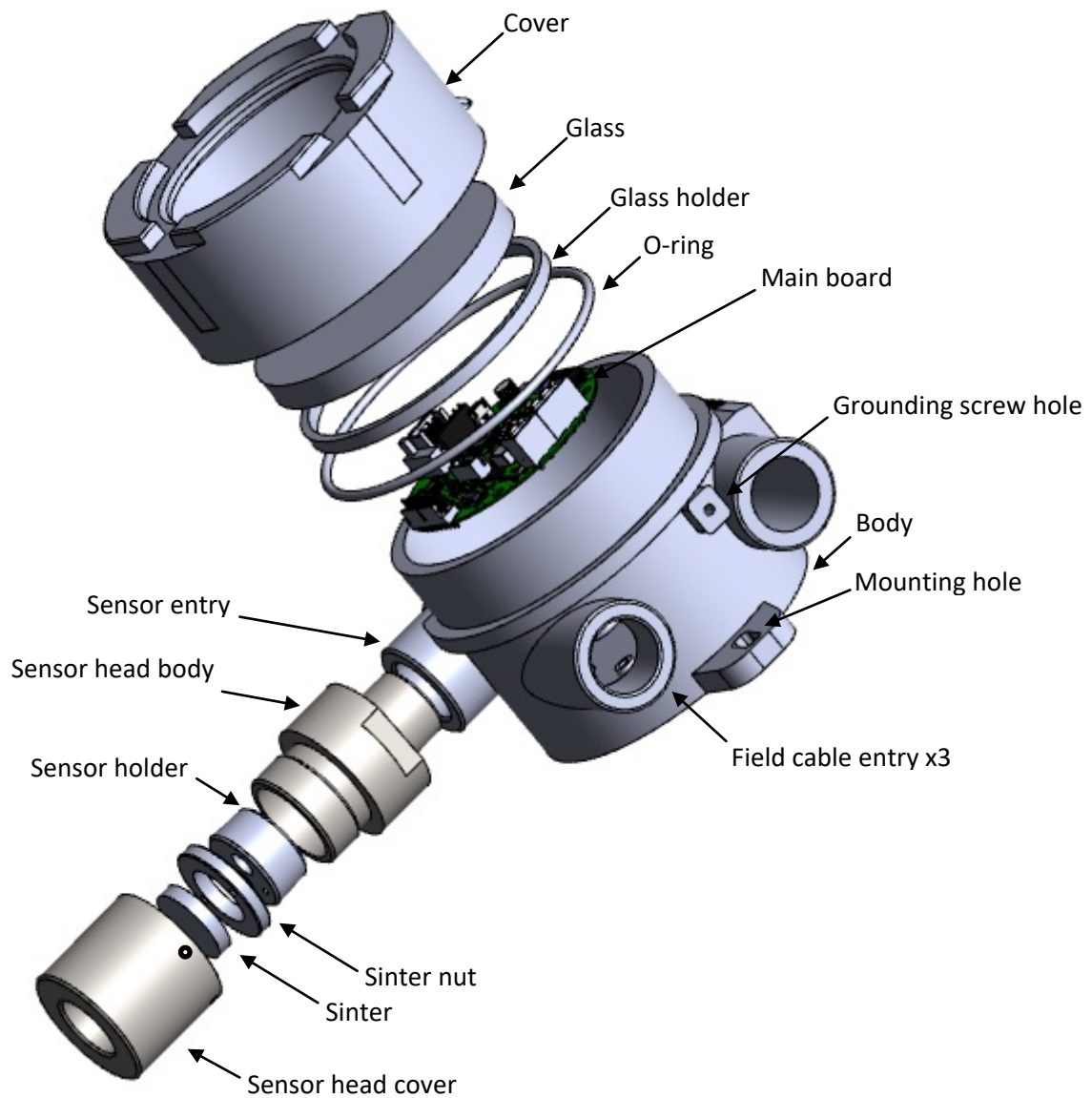

Diagram 2: Exploded view of PQD detector



ATEX certified Sensor Head must be used in hazardous atmosphere.

According to the ATEX Directive 2014/34/EU the detector is an assembly consisting of three components (Sensor Head, enclosure and cable gland), where all these three components are type approved according to ATEX Directive 2014/34/EU and marked by the device category II 2G. Thus this detector is suitable to be operated in hazardous areas with potentially explosive atmospheres of zone 1 and zone 2. The PQ series detector comprises a gas sensor type Ex-proof (protection type flameproof enclosure **db** type).

Detector body

The detector enclosure has four threaded entries. The two cable entries either side of the upper part of the transmitter housing are for connecting the power source, signal output and relay contacts to associated signalling equipment. The bottom entry allows direct connection of the sensor socket. There are two mounting holes incorporated into the transmitter housing.

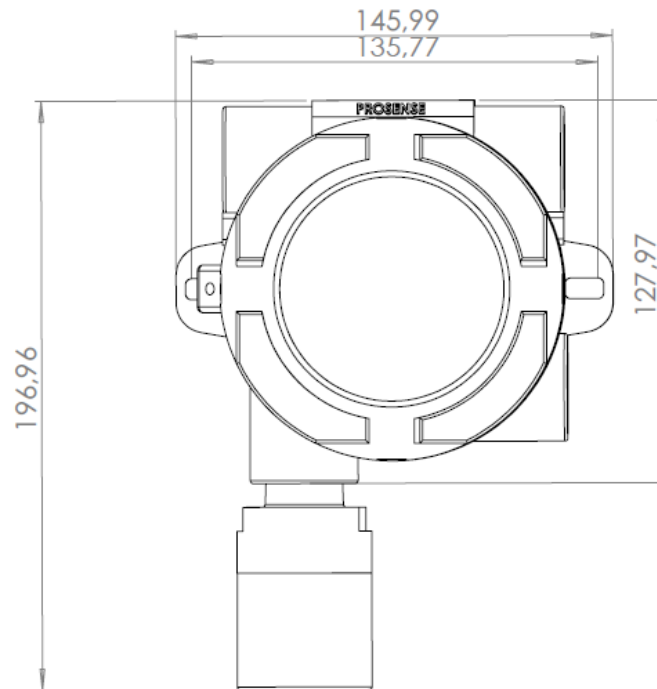

Diagram 3: Detector body and Sensor Head

Detector body has four entries and depending of the type selection their size and type will be different. The type information can be easily checked from the label as it mentioned with T code. For example PQD-3135 T1 means the detector body uses TYPE 1 body. The entries shown in Diagram-4:

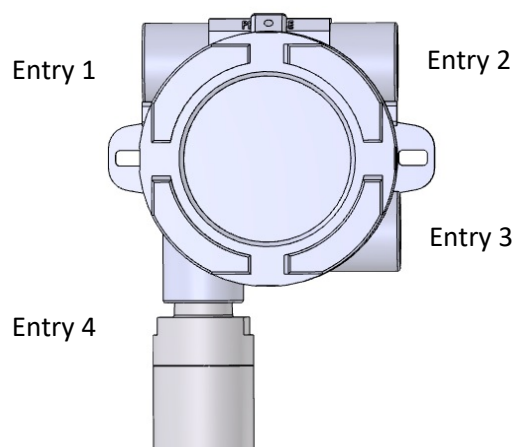

Diagram 4: Detector body cable entries

The entry specifications related to detector body are given in table-1 below:

Type	Entry 1	Entry 2	Entry 3	Entry 4
TYPE 1	1/2" NPT	1/2" NPT	1/2" NPT	3/4" NPT
TYPE 2	3/4" NPT	3/4" NPT	3/4" NPT	3/4" NPT
TYPE 3	M20	M20	M20	3/4" NPT

Table 1: Detector body types and entry specifications

Sensor Head

The Prosense sensor head designed to detect flammable, toxic and oxygen gases. Sensor head may include Infrared, pellistor and a wide range of toxic gas sensors based on electrochemical cell (ECC) technology.

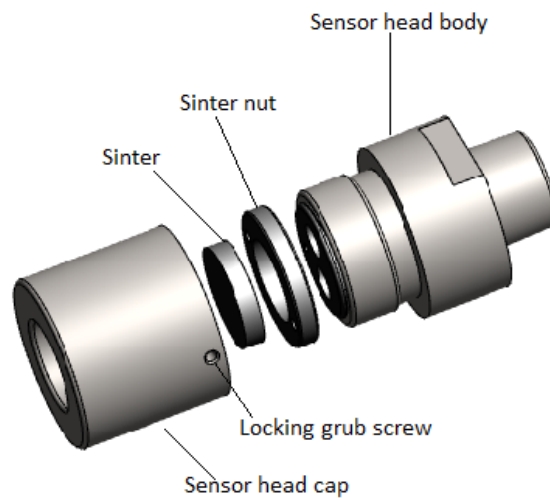

Diagram 5: Sensor Head components



ATEX certified Sensor Head must be used in hazardous atmosphere.

Installation

Gas detectors should be mounted where a potential hazard of gas is most likely to be present. The following points should be noted when locating gas sensors.

- When locating detectors consider the possible damage caused by natural events e.g. rain or flooding.
- Consider ease of access to the gas detector for functional testing and servicing.
- Consider how escaping gas may behave due to natural or forced air currents.

Note: The placement of gas detectors should be determined following the advice of experts having specialist knowledge of gas dispersion, experts having knowledge of the process plant system and equipment involved safety and engineering personnel. The agreement reached on the location of detectors should be recorded.

Each gas has different nature depending on their density. The density of which is lower than air, such as hydrogen, methane or ammonia the sensor head must be located above a possible leak or at the highest points at which major concentrations of gas may be found. The gases and vapours with a density greater than air, the sensor head must be installed beneath a possible leak or at the lowest points at which such gases and vapours may be present.

Prosense may provide cable gland together with detector in regards to customer requests. The cable gland provided by Prosense has ATEX certification and provides at least IP65 level protection. The cable glands are only suitable for fixed installations. Cable gland body should be fixed to related entry with 20Nm torque. Cables shall be effectively clamped to prevent pulling or twisting. To provide necessary protection cable gland coupling should be fixed with 20Nm torque when used with three sealing; 18Nm when used with two sealing; 16Nm when used with one sealing. It is the final assemblers'/users responsibility to ensure the threaded joint between cable gland and the enclosure meet all the requirements of the applicable standards for the assembly. Cable gland sealing are suitable for the circular type cables. If other shaped cables will be used the sealing should be replaced with suitable ones. The cable glands provided by Prosense are suitable to use temperature range in which detector works.

Prosense may provide plugs and adaptors together with detector in regards to customer requests. The plugs and adaptors provided by Prosense have ATEX certification and provide at least IP65 level protection. These parts should be mounted to detector body in such a way that accidental rotation or loosening will be prevented. Plug should be fixed to related entry with 20Nm torque. It is the final assemblers'/users responsibility to ensure the threaded joint between fitting and the enclosure meet all the requirements of the applicable standards for the assembly. For adaptors and plugs with nominal size of thread equal or lower than 25 mm aluminium alloy shall not be used. Only one adaptor permitted for each cable entry; plugs shall not be used with adaptors. The plugs and adaptors provided by Prosense are suitable to use temperature range in which detector works. The user-supplied cable gland, plug and adaptor must be ATEX certified. Components that do not have an ATEX certificate cannot be used.



If temperature exceeds 70°C at entry or 80°C at branching point use suitably rated cable and cable glands or conductors in conduit.

Mounting the detector

The detector should be mounted vertically as the sensor head pointing downwards. Detector has to be mounted such that the sensor's gas entrance area. The install location

- should be isolated from vibration, direct sun light and have temperature stability
- avoided external influences such as splashing water, oil, corrosive aerosols
- should have at least 30 cm free space beneath the sensor head to provide accessibility for calibration work.
- should be in air flow between possible leak or collection point and possible source of ignition.

Prosense do not recommend installing detectors to:

- directly above a cooking unit,
- directly above a sink unit,
- close to an extractor unit,
- outdoor without protection against the rain,
- in places where temperature is outside the admissible operating range,
- corrosive environments,
- inside air vents.
- environments where silicon can be found.

Prosense PQ series detector has mounting two mounting holes on detector body to fix detector directly to a surface:

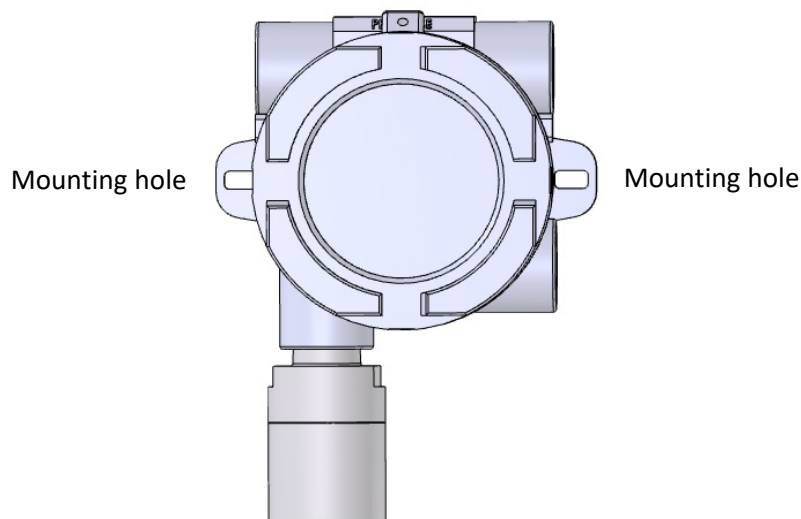

Diagram 6: Mounting holes

Electrical connections

Caution: All electrical connections should be made in accordance with any relevant local or national legislation, standards or codes of practice.

Prosense detectors can operate between 12 - 24 VDC. The connection socket located on main board as given in Diagram-11 (page 19) and details given in below table 2:

Output	Usage
V +	Power input (+) 12VDC – 24VDC
V -	Power input (-) 12VDC – 24VDC
S	Current Output Signal (4mA – 20mA)

Table 2: Detector output ports and their usage

The detector designed to give 4 - 20 mA current output signal. It is also possible to get voltage value via using an additional resistor. Below Table-3 gives recommended resistor specifications to get correct voltage output from detector depending of the desired signal level:

Detector Power VDC	Resistor	Signal level (4mA – 20mA)
12 VDC – 24 VDC	250 Ω, tolerance %1	1 VDC – 5 VDC
12 VDC – 24 VDC	500 Ω, tolerance %0,1	2 VDC – 10 VDC

Table 3: Detector power and the output resistor

Please consider the cable length when performing installation in the field. The Prosense detector requires a power supply between 12VDC and 24VDC. Make sure that a minimum 12 VDC supply available at the detector entrance and consider the voltage drop due to cable resistance in case of long distance applications. The maximum loop resistance in the field cable is calculated as follows:

$$R_{loop} = (V_{controller} - V_{detector\ min}) / I_{detector}$$

Example;

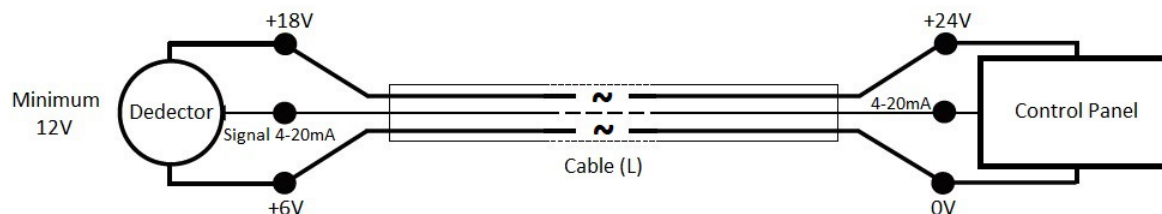

Diagram 7: Field cabling

The controller or power supply is supplying a nominal 24VDC (V controller), the detector minimum allowable voltage is 12VDC (V detector min), therefore the maximum allowable voltage drop between the controller and detector is 12VDC; this means a voltage drop of 6V in each core (V+ core and V- core).

Minimum power consumption of the detector without any optional module is 1W. The current required to drive the detector at the minimum voltage is $(I = P / V) : 1.0 / 12 = 85\text{mA}$ (I detector).

Maximum power consumption of the detector when optional relay modules installed and all relays are active is 4.0W. The current required to drive the detector at the minimum voltage is $(I = P / V) : 4.0 / 12 = 335 \text{ mA}$ (I detector).

So, the maximum field cable loop resistance (R loop) = $12 / 0.335 = 36 \text{ Ohms}$, or 18 Ohms per core, (allowing for component variations, losses, etc.).

The following tables show the maximum cable distances between the controller and transmitter assuming a voltage drop of 6V in each core and for different cable parameters. The tables are examples only and actual cable parameters and source power supply voltage for the application should be used to calculate the maximum cable distance allowed at the installation site.

Typical cable data for detector with relay module given in Table-4:

Cable size (cross sectional area)	Cable type nearest equivalent	Cable resistance Ω/km	Maximum Cable length (L) Meters
0.5mm ²	20AWG	36.8 Ω/km	~400
1.0mm ²	17AWG	19.5 Ω/km	~700
1.5mm ²	16AWG	12.7 Ω/km	~1100
2.0mm ²	14AWG	10.1 Ω/km	~1400
2.5mm ²	13AWG	8.0 Ω/km	~1800

Table 4: Typical cable details and maximum distance for cabling

Cabling

The use of industrial grade, suitably shielded field cable is recommended. The best practices shown that, screened 3 cores (plus screen 90% coverage), suitably mechanically protected copper cable with a suitable explosion-proof gland, or ¾" NPT steel conduit, depending on the distance between signal received or control panel and detector 0.5 to 2.5 mm² (20 to 13 AWG) conductors can give better results. Ensure the cable gland is installed correctly and fully tightened.



If the working conditions requires running equipment over Tamb +60C please use suitable cable.

Cable and Earth/Ground regimes

Effective Earth/Ground bonding is important to ensure good EMC and RFI immunity. The following diagram show example of how to earth/ground bond the cable at enclosures. The same principles apply to conduit installations. These bonding techniques provide good RFI/EMC performance. Earth/ground loops must be avoided to prevent the risk of false signal variation.

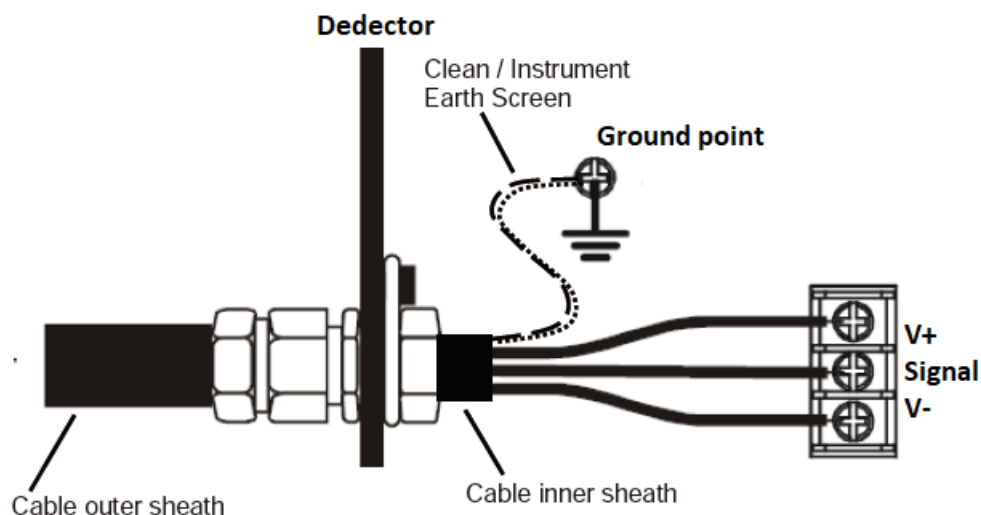

Diagram 8: Grounding

The Earth Screen of the field cable should be “tied to Earth” or connected to Ground at one point only. It is common practise to adopt a STAR EARTH connection regime where all instrumentation Screens are connected at one common point. The Screen at the other end of the cable should be “parked” or terminated into a blank terminal.

Detector grounding

Internal Ground connection: Each detector has grounding screw which utilizes grounding for detector main PCB to detector body. The screw should be located correctly and fixed for all times. In case of any maintenance activity this screw should be checked and fixed to make sure for proper grounding.

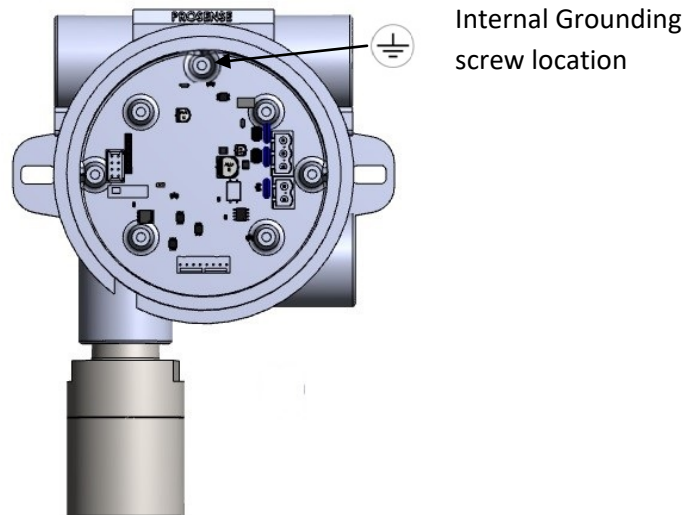

Diagram 9: Detector internal grounding screw location

Internal grounding screw location should be reserved for grounding cable and not used for any other purpose.

External Ground Connection: The detector body has two grounding locations as shown in Diagram-9. It is recommended to utilize a No 14 AWG copper, (Stranded or Solid), wire.

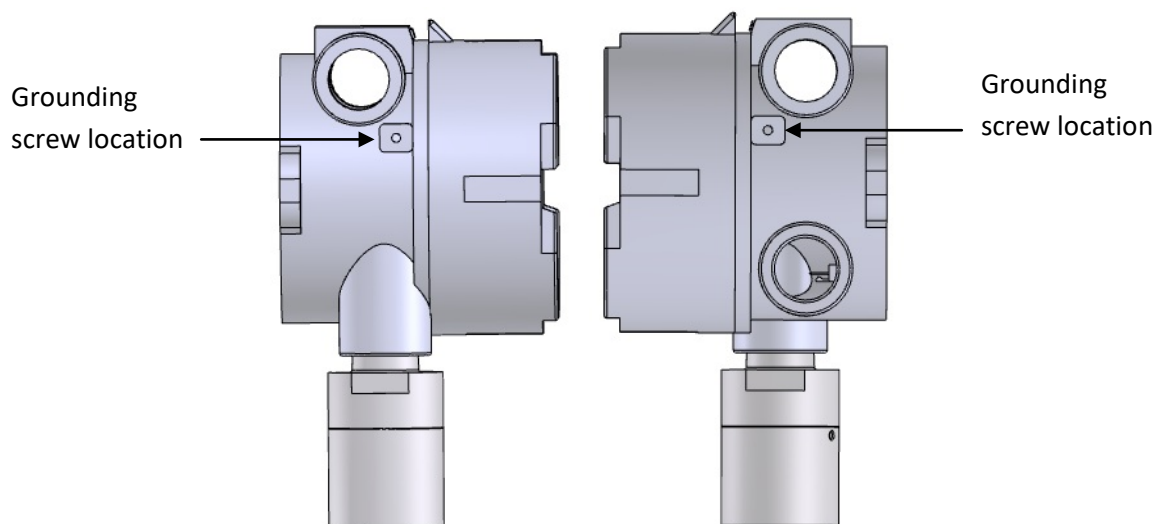

Diagram 10: Detector grounding locations

Default configuration

Prosense detectors preconfigured to provide signal from analogue output depending on the detector and gas type:

Function	Value/Setting	Meaning
Signal output	2.0 mA	Fault
	2.0 mA to 3 mA	Warm-up
	3mA	Calibration mode
	4.0 mA to 20.0 mA	Normal gas measurement
	21.0 – 22.0 mA	Maximum over range

(*) Relays are only available with optional relay module

Table 5: Detector default configuration details

Detector Main board and connection details given in Diagram-11:

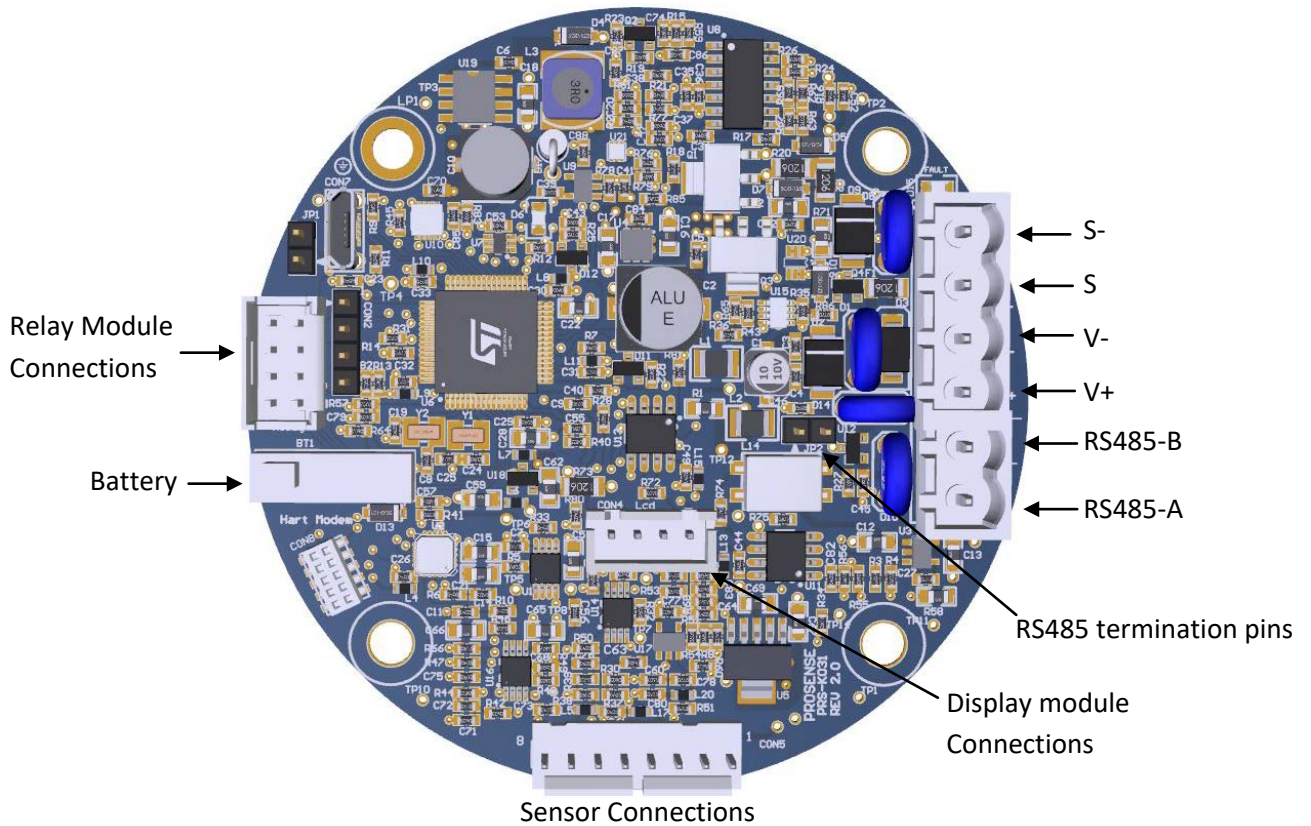

Diagram 11: Detector main board and connections

Sensor connections are input to detector main board and already connected to sensor inside the sensor head. Detector connections are listed in Table-6:

Port	Usage
V +	Power input (+) 12VDC – 24VDC
V -	Power input (-) 12VDC – 24VDC
S	Current Output Signal (4mA – 20mA)
S-	Current Output Signal (4mA – 20mA)
RS485-A	Serial connection port A
RS485-B	Serial connection port B

Table 6: Detector output ports and their usage

Detector Configuration

The Prosense PQ detector has 4-20mA analogue output and RS485 Modbus serial communication output features on main board. It is possible to install optional relay module to have three relay outputs for two alarm levels and fault status.

4-20 mA output:

The default configuration provides single 4-20mA signal output. Prosense detectors can be connected to control panels on the market having 4-20mA input signal. Signal wiring from detector and the control panel should be carried out by shielded cables. Wires cross section depends on the distance between the control panel and the detector. The details given in power cabling are valid as well for signal output. We recommend using values given in Table-4 as cabling best practices.

Please avoid any interruption in case any junctions on wires. The shield is to be grounded from the control panel side only and never connect the shield to the detector. Please make sure clenching or crimping apparatus are not loosened or oxidized.

To get the analogue output signal correctly and constant the load resistor on S output should be between 100-500 Ohms. If the load on S port drops below 100 Ohms the detector will behave as the S output is in short circuit status and enable the automatic output saving mode resulting with reducing signal level to 2mA.

RS485 serial communication output:

Prosense PQ series detector has RS485 serial communication output on main board. Connection ports are located on a different socket nearby analogue output and power input ports. User should prepare two wire additional cables when RS485 communication used. To use the detector with RS485 serial communication, a four-wire connection should be done which are energy input (V +, V-) ports and RS485 (A, B) ports. Even if only the RS485 connection is to be used, the S end must have the required load resistance. If both analog current output and RS485 serial communication terminals are to be used at the same time, a five-wire connection must be made to connect the terminals on both sockets (V +, V-, S, A, B). The total length of the connection line should not exceed 800 meters. The wiring for detectors utilized with RS485 board should be done by using connection cable EIA RS485 2 core wires with section 0.22 / 0.35 mm² and shielded. Nominal capacity between the wires should be < 50pF/m and nominal impedance 120 Ohms.

Detectors will be wired in daisy chain (bus) mode. We recommend not using star mode connection due to negative impact of interference. Each detector should have unique address number in the chain. The detectors would not be recognised by control panel if same address given to them. The address of detector can be adjusted via using configuration

hand module or display. Detectors can be assigned to use addresses from 1 to 247 (including 247). Address zero (0) cannot be used by detectors.

The last detector in the chain should have 120 Ohms RS485 termination resistor. The resistor is already implemented on the board by default but not activated. User should activate the termination resistor via using the RS485 termination pin shown on Diagram-11 once the installation completed.

Detector Relay module:

Prosense provides optional relay modules for Prosense PQ detectors. The relay module details are given below:

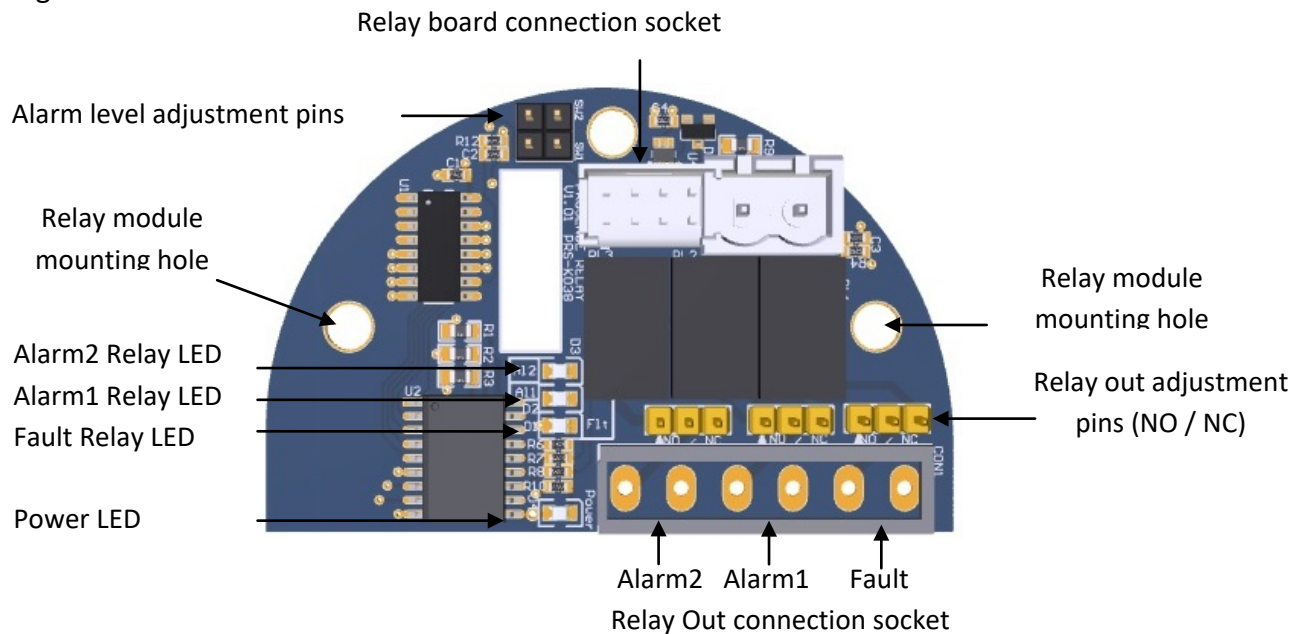

Diagram 12: Relay module

The relay board has 3 relay outputs:

Port	Usage	Energy	Contact (NO / NC)
Fault	Fault Relay output	Energised	NO
AL1	Alarm 1 Relay output	Non-Energised	NO
AL2	Alarm 2 Relay output	Non-energised	NO

Table 7: Relay module output ports

Each relay has 3 pins grouped on board to adjust how to behave in case of alarm which are NO: Normally Open

NC: Normally Close

The relay output pin positions shown below:

	Normally Open (NO)
	Normally Close (NC)

Table 8: Relay output pin positions

The relay module set to NO (Normally Open – De-Energised) position at factory. The Fault relay is set to NO (Normally Open – Energised). It will be de-energized in case of power failure. This helps user to easily identify any power outage on detector side.

The alarm levels are also adjustable via using SW1 and SW2 alarm level pins. Alarm levels are defined as percentage in LEL for flammable gases. The alarm levels can be adjusted using jumpers to switch SW1 and SW2. Possible options are given in table-9:

SW1	SW2	AI1 Level (LEL or PPM)	AI2 Level (LEL or PPM)
Open	Open	10 %	15 %
Open	Closed	10 %	20 %
Closed	Closed	20 %	25 %
Closed	Open	20 %	40 %

Table 9: Alarm level pin positions (for % LEL or % PPM)

Alarm levels can be adjusted via user menu in PQD models. These settings will overwrite to SW1 and SW2 settings.

The alarm levels for toxic gases are defined with the same percentage level of the measurement range as given in the table. For example an Ammonia detector with 0-100 ppm range will provide alert at 10ppm while SW1 and SW2 is open. If the measurement range is 0-300 ppm for the ammonia detector the first alarm will be released at 30ppm.

Oxygen detectors:

For oxygen detectors the output values and meanings are different as oxygen is naturally available in atmosphere:

Port	Usage
Fault	Fault Relay output
AL1	Alarm 1 Relay output - Lower level for Oxygen
AL2	Alarm 2 Relay output - Higher level for Oxygen

Table 10: Relay module output meanings for Oxygen detectors

Alarm levels are also different as given in below table:

SW1	SW2	AI1 Level	AI2 Level
Open	Open	19 %vol	23 %vol
Open	Closed	19 %vol	22 %vol
Closed	Closed	18 %vol	22 %vol
Closed	Open	18 %vol	23 %vol

Table 11: Alarm level (% Vol) pin positions for Oxygen detectors

In PQD model detectors, alarm levels and relay outputs can be set to the desired value except for lower or upper level definitions given for oxygen. Both alarm levels can be used for decreasing or increasing values.

System Status

The Prosense PQ detector has a screen to show status messages and measurement levels online. Also it has five LEDs to show power, fault, alarm1, alarm2 and alarm3 status. If all is fine the green power LED will lit and screen will show the gas that detector measuring, current level of gas detector reading, data and time information, ambient temperature and a bar to show level of current gas measurement.

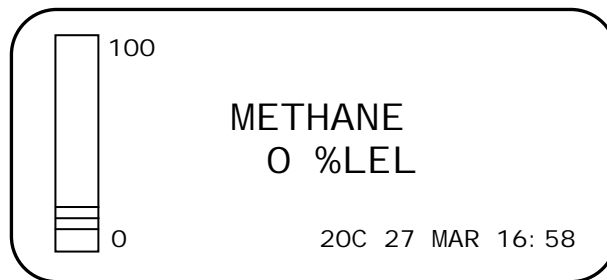

The detector will need to warm-up to be ready when power applied. During this 2 minutes warm-up period the status messages shown on upper right side of the screen. Also Fault LED will be lit.

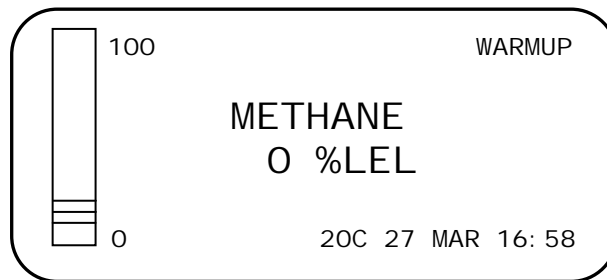

If detector is in fault condition Fault LED will be lit, screen show fault message and the detector analogue output gives 2mA on S port. If detector could not get enough power (lower than 12 VDC) it will also raise fault status.

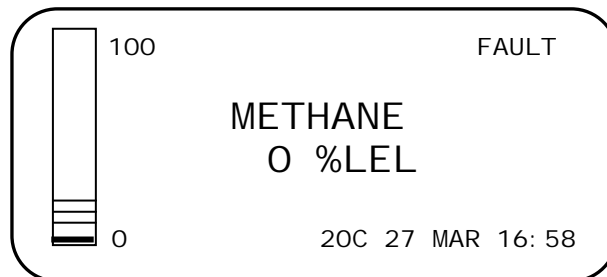

In case of an alarm, related alarm LED will lit and alarm information will be shown on the screen:

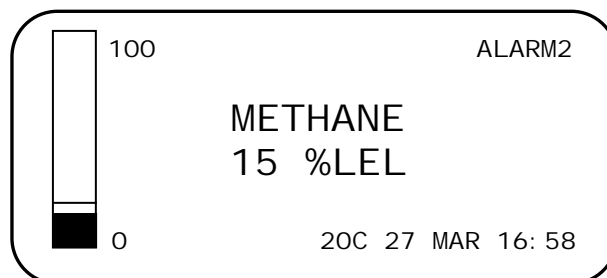

Commissioning

WARNING

The following procedure requires the detector cover to be removed while carrying out supply voltage checks. Therefore, the appropriate permits to work should be sought in preparation.

Prior to carrying out any HOT WORK ensure local security and site procedures are followed. Ensure that the associated control panel output actuation is inhibited so as to prevent false alarms.

Caution: The following procedure should be followed carefully and only performed by suitably trained personnel

Commissioning PQD

1. Remove the detector cover. Gently remove the display board from its location.
2. Configure the detector's analogue output signal and power input connections correctly
3. Check that all electrical connections are terminated correctly
4. Switch On the external power supply to feed the detector
5. Using a Digital Multi Meter (DMM), check the Supply Voltage at the terminals V+ (24V) and V- (0V), this should be a minimum supply voltage of 12VDC (Maximum supply voltage is 24VDC)
6. Check LED status on detector main board. LED will be illuminated right after applying power.
7. Check the screen. It will run self check tests and report the results. All tests should end with OK. In case of any ERROR message contact Prosense.
8. When test completed the screen will show monitoring screen with detector information and WARMUP message on status line. The Fault LED is lit in this period.
9. Wait two minutes to see WARMUP message removed from status line and fault LED gone off.
10. Switch Off the external power to the detector.
11. Fix the screen board to its location. Fit the cover and make sure none of the cables cause an obstruction while fitting cover. Fix the cover locking grub.
12. Switch on external power to the detector.

Commissioning PQN

1. Remove the detector cover
2. Configure the detector's analogue output signal and power input connections correctly
3. Check that all electrical connections are terminated correctly
4. Switch On the external power supply to feed the detector
5. Using a Digital Multi Meter (DMM), check the Supply Voltage at the terminals V+ (24V) and V- (0V), this should be a minimum supply voltage of 12VDC (Maximum supply voltage is 24VDC)
6. Check LED status on detector main board. LED will be illuminated right after applying power.
7. LED will start blinking twice in a second during the warm-up period and analogue output signal will provide 3mA.
8. Wait two minutes to complete warm-up period. The LED on main board will switch blinking once in a second and analogue output signal will be 4mA.
9. Switch Off the external power to the detector.
10. Fit the cover and make sure none of the cables cause an obstruction while fitting cover. Fix the cover locking grub.
11. Switch on external power to the detector.

Detector Settings

Prosense PQ detector prepared at factory to work as standalone detector. User may want to change settings and alarm levels depending of the usage. PQD detector screen can be used to change the detector settings. A magnet provided with detector to perform detector configuration changes. The 3 keys on display will be used to perform any operation which are Enter, up (Increase) and down (decrease). The Enter key needs longer touch (2 seconds) with magnet while up and down keys can operate 1 second touch. If user wants to cancel any operation on any screen keep magnet on Enter key till the screen return back to previous screen.

PQN Series detectors will have same functions, options and screens when used with a hand terminal. The hand terminal provided by Prosense and can be used to setup or maintain the detector.

Entering the menu:

To reach configuration menu press Enter. The screen will request password information:

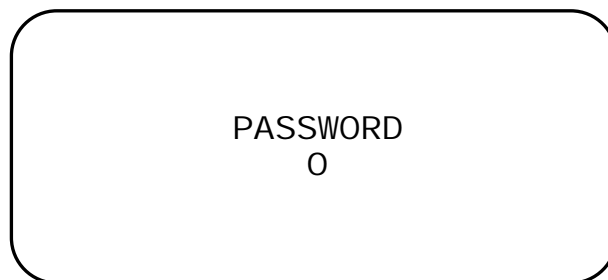

The password is 1234. You need to set values via using up and down keys. Once the value is set press Enter again to confirm and move to the next digit. Confirmed digits will be made invisible by detector program:



The screen will display menu options when correct password entered at last digit:

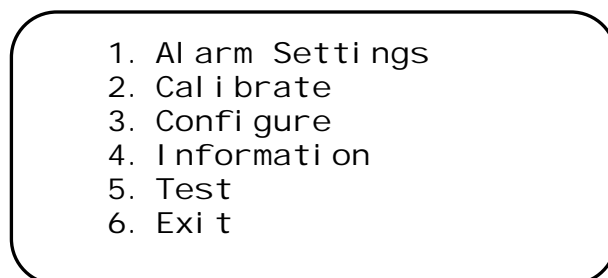

Menu structure

PQ Detector menu includes all necessary steps to setup detector and display information.

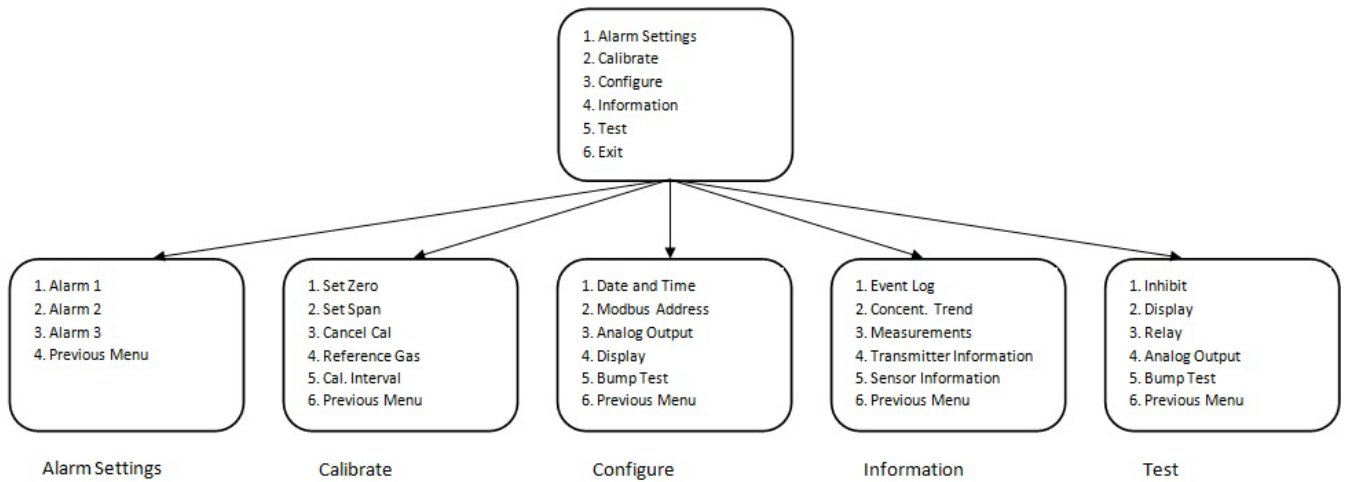

Diagram 13: Main menu structure

Alarm Settings

Alarm levels can be adjusted via using alarm menu steps. Alarm menu general structure is given in diagram-12:

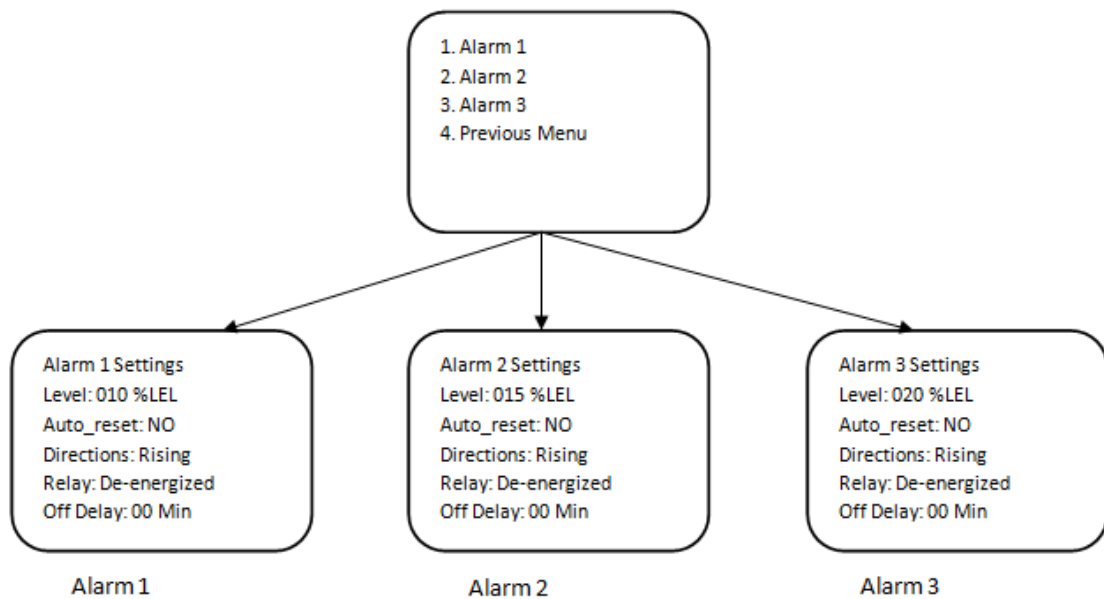
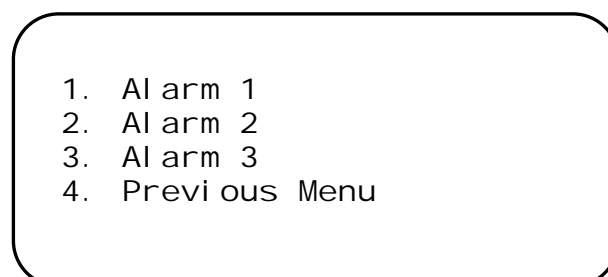
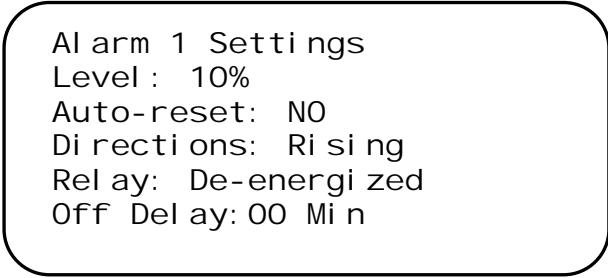

Diagram14: Alarm menu structure

Once you reach the main menu the first option is alarm settings. Press Enter to move the alarm settings menu. A new menu listing alarm levels will be shown:



Please select the alarm level you would like to adjust and press Enter key to see details. All alarm details will be listed in new screen and parameters will be blinking one by one while you set the values.



Alarm 1 Settings
Level : 10%
Auto-reset: NO
Directions: Rising
Relay: De-energized
Off Delay: 00 Min

The first digit of the first alarm will start blinking to let you increase or decrease the digit via using up and down keys. When you set the value, press again Enter key to move next digit. The next digit will start blinking to allow you set desired value. When you complete, press Enter key long enough. The display will show “Successful” message and return back to higher level menu.

All alarm levels have same parameter that user can adjust if needed. Otherwise they will work with their default settings. The meaning of parameters is as follows:

Level: The measurement level to raise the alarm

Auto-reset: Define how the alarm relays will work. If ‘YES’ selected the relay will be released once the measurement level returned to normal. If ‘NO’ selected the relay will lock in their position.

Directions: Parameter to define in which way alarm will be activated whether increasing or decreasing. For most toxic and flammable gases it will be raising, for oxygen it can be both raising and falling.

Relay: It defines the alarm relay working conditions. Relays can be programmed as Energized (NC) or Non-energized (NO) contact according to use cases and scenarios. When Energized is selected, the relay will have energy during normal operation. When Non-energized is selected, the relay is only energized when performing the switching function.

Off Delay: To define the delay while alarms and relays performing activation or deactivation functions. This function must be adjusted according to operating conditions and safety rules. For example, in some plants ventilation fans kept activated after the measurement level falls below the alarm level. In such cases the off delay feature can be used. The off-delay can only be defined in minutes.

Configure

User can change the parameters of detector depending of the usage such as date, time, password and detector address via configure menu. Select 'Configure' step on main menu to perform changes. A new menu options will display with options:

1. Date and Time
2. Modbus Address
3. Analog Output
4. Display
5. Bump Test
6. Previous Menu

The Configure menu structure is given in below diagram:

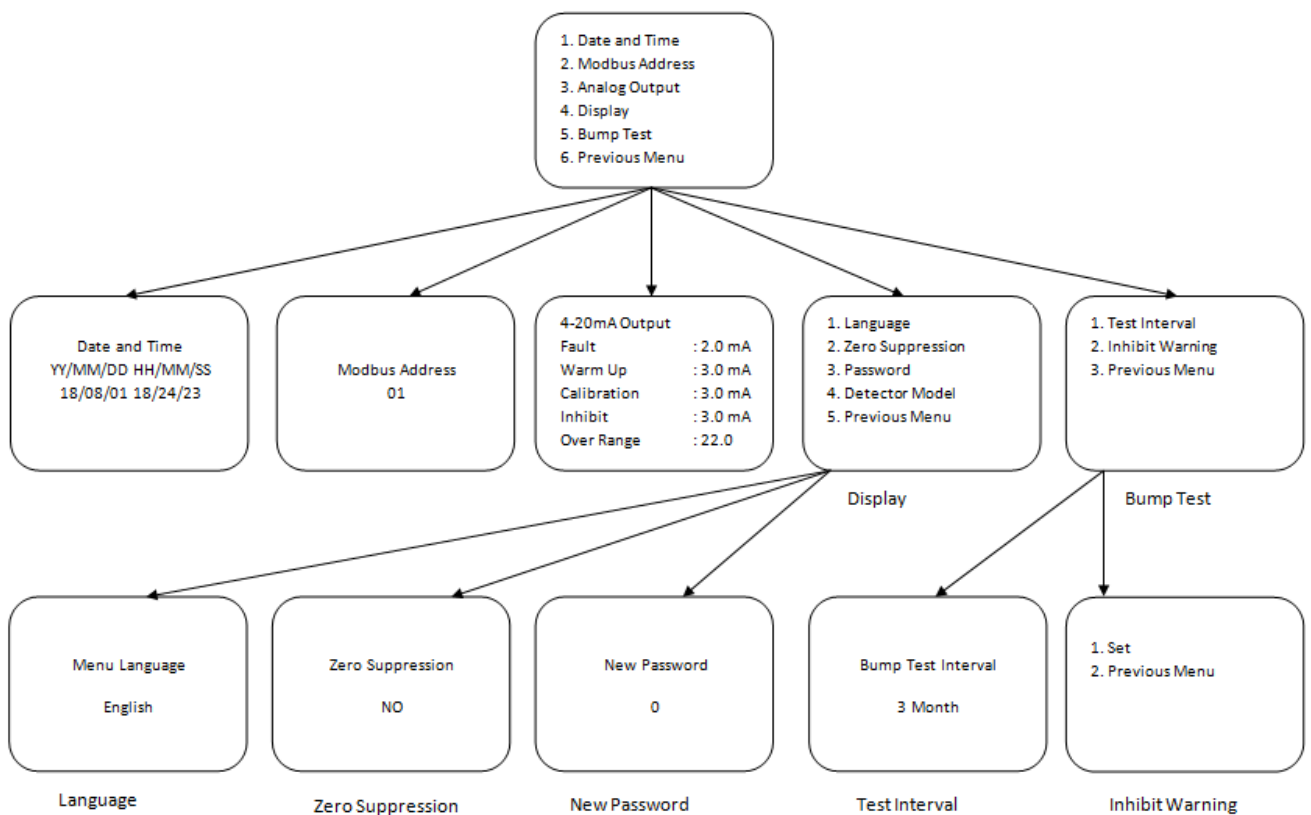

Diagram15: Configure menu structure

Change date and time

To change date and time select first menu item. Display will show date and time details:

Date and Time
YY/MM/DD HH/MM/SS
18/03/27 15/38/27

The first digit on screen will start blinking once entered the menu step. You can increase or decrease the value via using up and down keys. Once desired value has been set press Enter key to confirm and move to the next digit to set. Once all set press Enter key. The display will show “Successful” message and return back to higher level menu.

Change Modbus address

To change detector address, select “Modbus Address” menu option. In RS485 communication detectors are slave devices and control panel is the master device. Each detector must have unique address to work together in same RS485 communication loop. Select “Modbus Address” menu item via using up and down keys and press Enter key. Display will show default detector address which is 1:

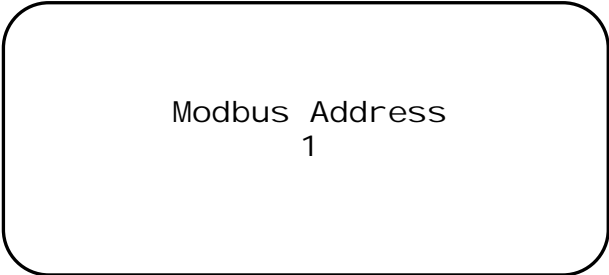

Address can be changed with up and down keys. Once set to desired address press Enter key long enough. The display will show “Successful” message and return back to higher level menu.

Change Analogue Output

User can adjust analogue output levels depending of the status and function. To do this please select “Analogue Output” menu item on configuration menu via using up and down keys and select Enter key. Screen will display default values used for analogue output:

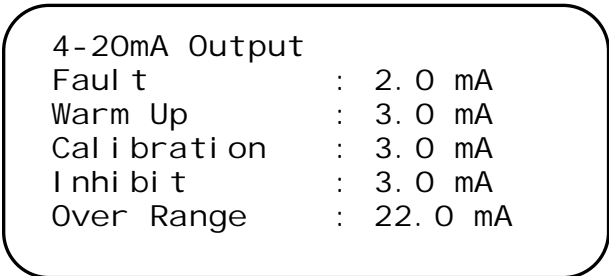

User can adjust these values to desired values depending of the application requirements.

Display Parameters

Detector display can be adjusted as per requirements. The display options are given in Display menu item

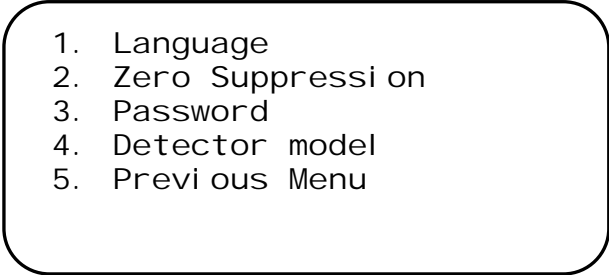

Change Language

The detector display language can be changed to English or Turkish. To change Language first select Configure option on main menu then select Display option and Language option. Once you reach to Language screen you will able to switch display language:

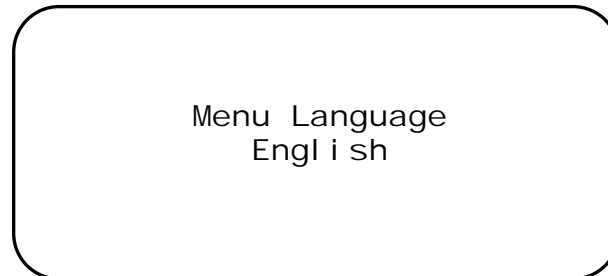

Change Zero Suppression

User can adjust the way showing measurement level around zero level. If zero suppression mode set to NO, detector will display measurement as detected. If zero suppression mode set to YES, detector will show measurement levels as 0 (zero) up to 3% LEL. At 3% LEL it will display measurements as detected.

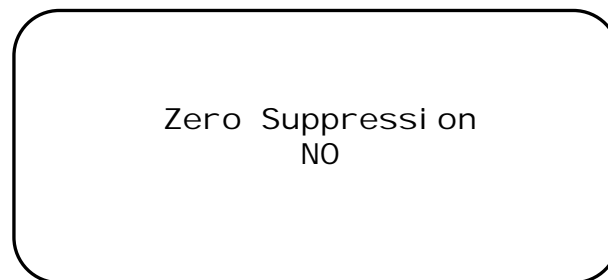

To change zero suppression mode select Zero Suppression option on Display menu and press Enter key. Current zero suppression mode will be displayed. If needed change the value via using up and down keys. Once adjusted press Enter key to record value.

Change password

User can change password. The default password is 1234. To change password select Password menu item via using up and down keys and press Enter key. Display will ask new password:

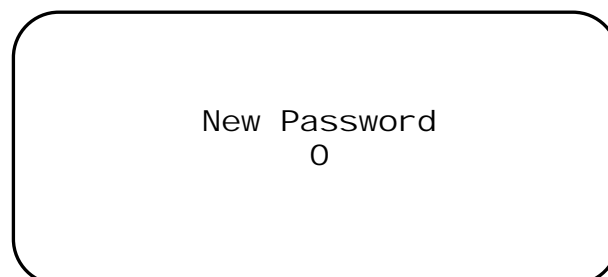

Password must be 4 digits and should be set digit by digit via using up and down keys. When completed, press Enter key long enough to confirm. The display will show "Successful" message and return back to higher level menu. User should remember the password to perform changes later on. If user forgets the password, detector should be returned back to

Prosense to reset password. No Field operation is available to reset password at customer site.

Detector Model

This menu step used to set detector model. PQ series detectors named as PQD if they have display module and PQN if they do not have display module. This menu step is used only at production and not necessarily to change at field at any time. Once entered to menu screen will display the selected model:

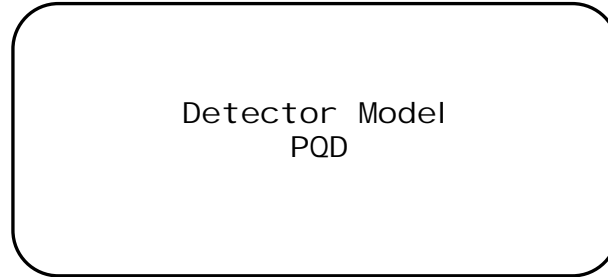

The model can be changed via up and down keys:

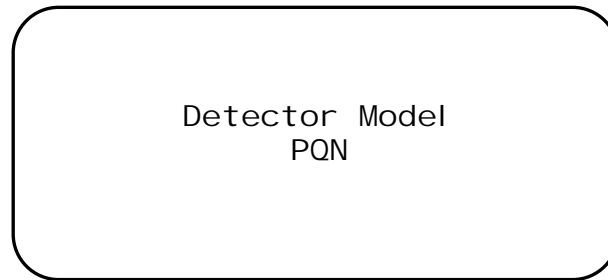

The detection function will not change with this setting. But detector will not report fault for display module errors if the model is incorrect. Hence this menu step should not be altered in the field.

Bump Test

Detectors should be tested to make sure they can perform their operations as defined. To do this bump test should be performed in defined periods. Bump test parameters can be adjusted via using Bump Test options in Configure menu. To start adjustments select Bump Test step on Display menu. A new screen will display with available options:

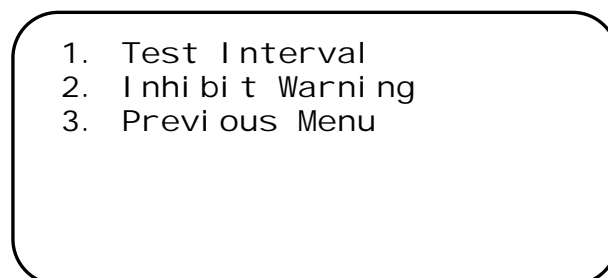

Change Test Interval

To change bump test interval select Test Interval option on Bump Test Menu.

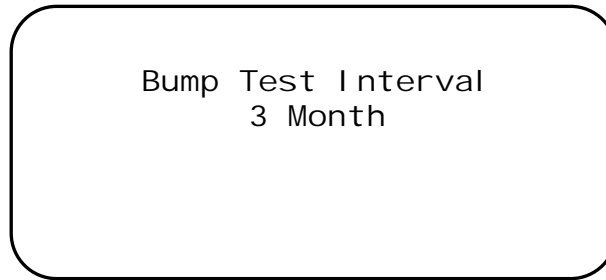

Once the bump test interval menu shown the time value will start blinking. User can change the value via using up and down keys. Select Enter key to save the value when adjustment done. The display will show "Successful" message and return back to previous menu.

Adjust Inhibit warning

User can set or clear inhibit warning via using Inhibit warning option on Bump Test Menu. To adjust warning please select Inhibit warning menu option. A new menu shown including possible adjustment option:

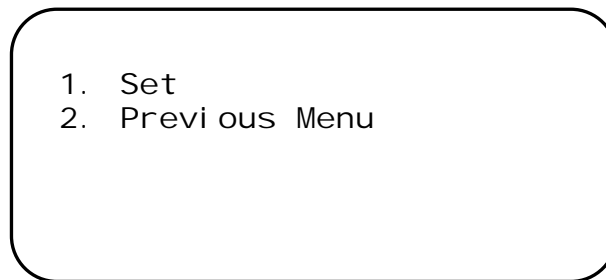

If inhibit warning already set, the screen will display clear option:

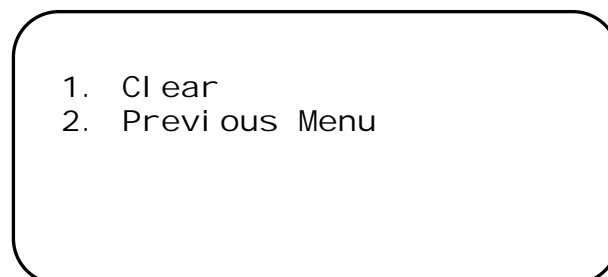

Once decided select the option and press Enter key. The display will show "Successful" message and return back to previous menu.

Information Menu options

Information menu provides more detailed information about measurements, events and device itself. The Information menu structure is given in below diagram:

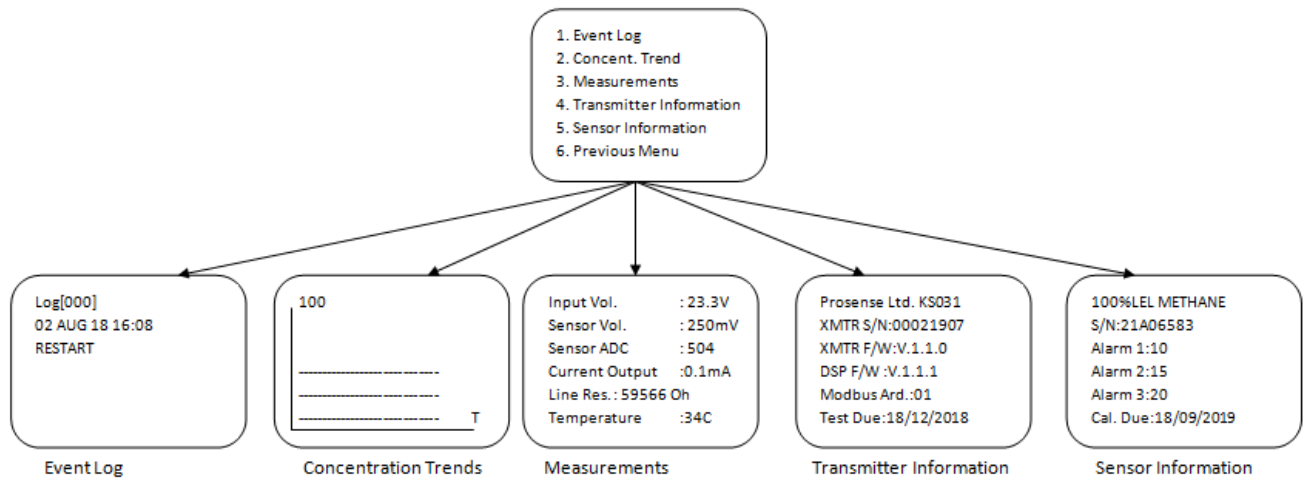
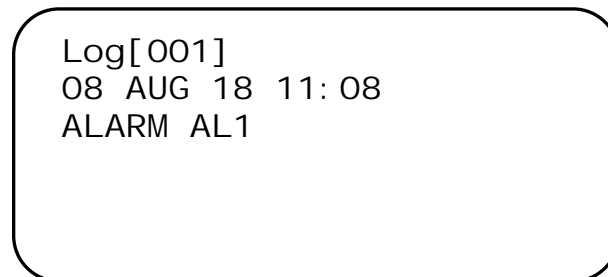

Diagram16: Information menu structure

Display Event Logs

Detector records all events starting from its power-on. To display recorded events, select Event log option in Information menu. Detector will list the events:



The screen can display only one event. To see all events use up and down keys. All events starting from first power-on has been saved in detector memory. It can store up to 250 events.

Display Concentration Trends

PQ detector can show gas concentration trends in screen as it is recording all the measurement data in last 8 hours. Once this option selected a graphic screen will shown to display gas measurements:

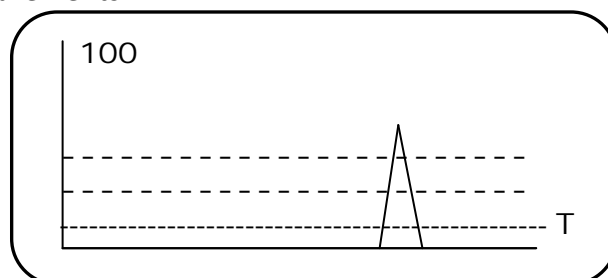

To return back to previous menu please press Enter key till the screen changes.

Display Measurements

To get more details about the measurements please select measurements option in Information menu. Detector will display the voltage, current and temperature levels as in below example:

```
Input Vol .      : 23. 3V
Sensor Vol .     : 2506mV
Sensor ADC       : 504
Current Output   : 4mA
Line Res.        : 300 Ohm
Temperature      : 34C
```

Display Transmitter information

To get details about transmitter and firmware level use transmitter information step in Information menu. A screen will display details.

```
Prosense Ltd. KS031
XMTR S/N: 00021907
XMTR F/W: V. 1. 1. 0
DSP F/W : V. 1. 1. 1
Modbus Adr. : 01
Test Due: 18/12/2018
```

To return back to previous menu please press Enter key till the screen changes.

Display Transmitter information

To get details about transmitter and firmware level use transmitter information step in Information menu. A screen will display details.

```
100%LEL METHANE
S/N: 036583
Al arm 1: 10
Al arm 2: 15
Al arm 3: 20
Cal . Due: 18/09/2019
```

To return back to previous menu please press Enter key till the screen changes.

Test Menu Options

User can execute tests to check detectors functions. Test menu structure is given in below diagram:

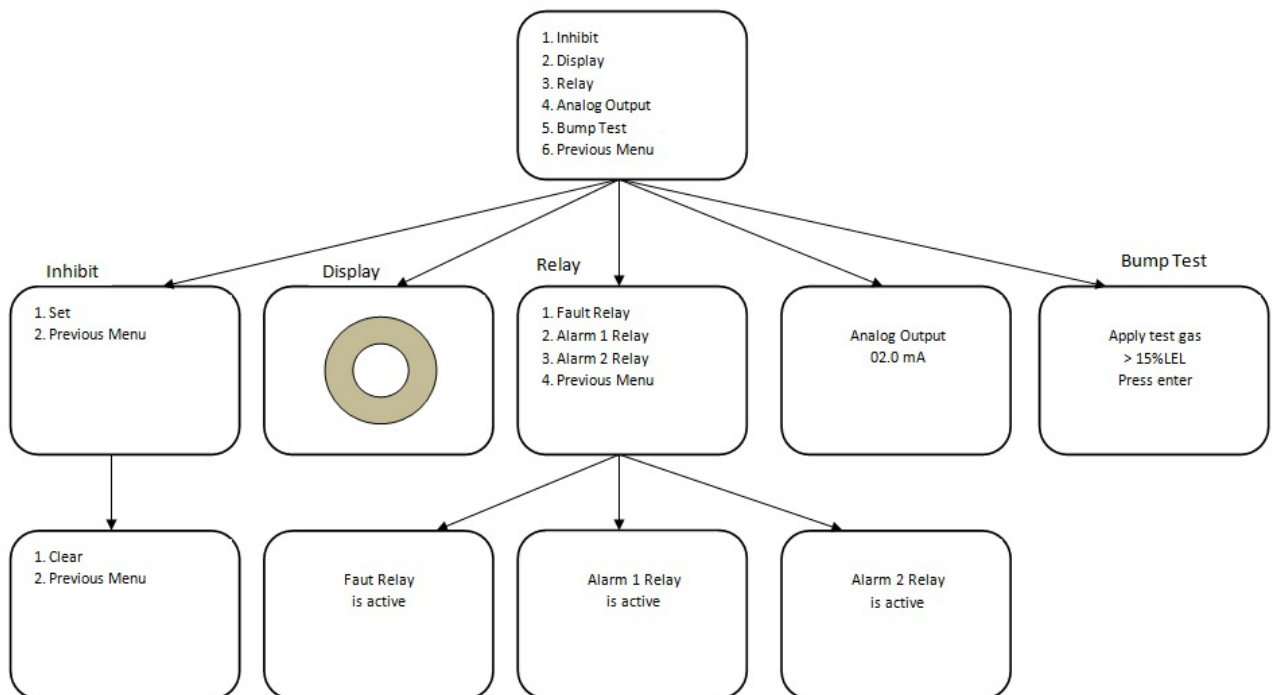

Diagram17: Test menu structure

To perform tests select Test menu item via up and down keys then press Enter key. The screen will display test options:

1. I n h i b i t
2. D i s p l a y
3. R e l a y
4. A n a l o g O u t p u t
5. B u m p T e s t
6. P r e v i o u s M e n u

To execute tests select desired test option and press Enter key. To return back to previous menu please select Previous Menu option and press Enter key.

Run Inhibit test

User can initiate detector to work in inhibited mode. In this mode detector will provide the signal level defined in configuration details for inhibited mode (default is 3mA) and the alarms will be deactivated. When Inhibit option selected in Test menu below screen will display to set inhibit detector:

1. S e t
2. P r e v i o u s M e n u

If user finish the work or test it is necessary to clear inhibit mode to return detector to normal operation. To do this user should re-enter to Inhibit menu in Test menu. The clear option will be displayed at this time:

- 1. Clear
- 2. Previous Menu

Run Display test

To execute display tests select Display option on Test menu and press Enter key. The detector program will start display test via drawing different patterns. It might take one minute to complete test. The display will return back to Test menu when test completed.

Run Relay test

It is possible to check relay functions via using menu options. Relays are only available if optional relay module installed on to detector main board. To run relay test please select test menu and select Relay option. Screen will display three options to test as there are three relays on relay module. Select the menu option related to desired relay test and press Enter key.

- 1. Fault Relay
- 2. Alarm 1 Relay
- 3. Alarm 2 Relay
- 4. Previous Menu

If fault relay test selected, detector will activate the relay and screen will display information:

Fault Relay
is active

If alarm relay selected, detector will activate related alarm relay and screen will display information:

Alarm 1 Relay
is active

To return back to previous screen please press Enter key till the screen updated with previous menu items.

Run Analogue Output test

To test analogue output level user can initiate the analogue output test in Test menu. Once Analogue Output option selected press Enter Key. Screen will display the analogue output level. User can increase or decrease the output signal level via using up and down keys.

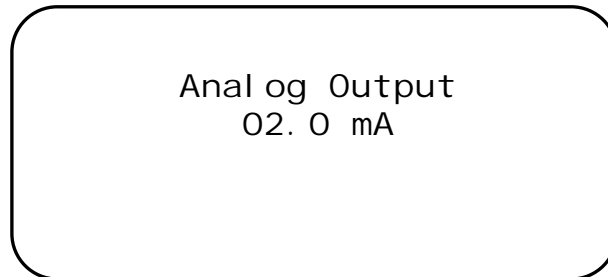

To return back from Analogue Output test please press Enter key till the screen updated with previous menu items.

Run Bump Test

Bump test can be run at any time when needed. The Bump test runs depending of the parameters defined for bump test in configuration details. To initiate bump test please select Bump test menu item in Test menu and press Enter key. Screen will display messages that requesting user to apply test gas and press Enter

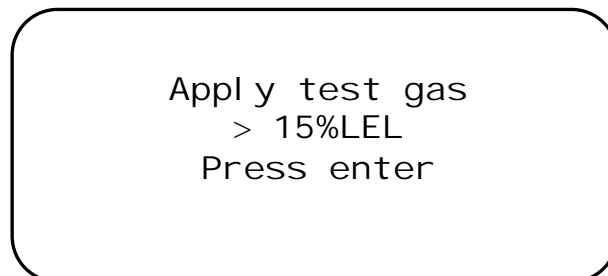

User should provide necessary gas and press Enter. The screen will return back to measurement screen and show the measurement for 30 seconds.

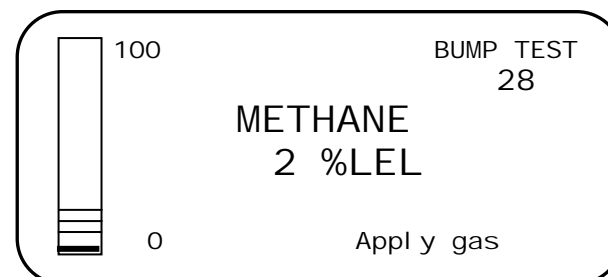

While test executed detector will automatically went in to inhibited mode and Fault LED will start blinking. After 30 seconds screen will alert user to remove the test gas from detector:

Remove applied gas

Detector will return to measurement screen for another 30 seconds with same message

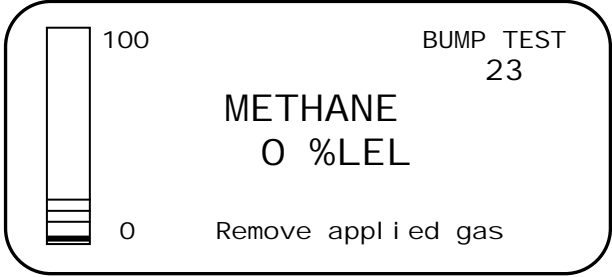

Once the time counted down to zero the screen will display test results:

Start Concentration
0%LEL
Peak Concentration
24%LEL
End Concentration
0%LEL
Test Result OK!

If test fails the screen will indicate the result

Start Concentration
0%LEL
Peak Concentration
24%LEL
End Concentration
0%LEL
Test Result FAILED!

Once test completed screen will display back to Test menu items.

Calibration

It is recommended to periodically carry out calibration to ensure correct operation. Prosense PQ series detector calibration includes two steps as zero and span calibration. It is possible to perform each step independently. Prosense recommends to perform both calibration steps to have correct calibration. Detector should be powered and stabilized for at least 4 hours before calibration. During the calibration phases the detector output is inhibited (default 3mA) to avoid false alarms. Zero calibration of infrared sensors should be done with N2 and zero calibration of other sensors should be done with zero air (O2 and N2 gas mixtures). For Flammable gas calibration use a calibration gas concentration of between 25%LEL and 75%LEL to ensure that the required accuracy can be attained. It is necessary to use international traceable gases.

To calibrate the detector, use an appropriate span gas cylinder, constant flow regulator and Prosense Gas Cap. Calibration gas should be applied with 0.5 lt/min flow rate.

It is recommended to use a compressed air cylinder (20.9%Vol oxygen) to perform the zero calibration if the area where the detector is located contains any residual amount of the target gas. If no residual gas is present then the background air can be used to perform the zero calibration.

To perform calibration procedure a hand terminal or screen is necessary. Attach hand terminal to detector and press Enter to reach menu. The screen will request password information:

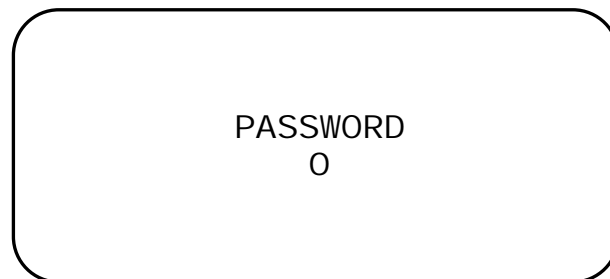

The default password is 1234. If user changed the default password use updated password. You need to set values via using up and down keys. Once the value is set press Enter again to confirm and move to the next digit. The digit confirmed will be made invisible by detector program:



If the password is wrong the display will return to measurement screen. The screen will display menu options when correct password entered at last digit:

1. Alarm Settings
2. Calibrate
3. Configure
4. Information
5. Test
6. Exit

Select Calibration. Screen will show calibration options:

1. Set Zero
2. Set Span
3. Cancel Cal
4. Reference Gas
5. Cal. Interval
6. Previous Menu

It would be better to first set reference gas details and calibration cycle period as these values cannot be altered once calibration started for zero or span. Zero or Span calibration can be performed separately at any time. It is recommended to perform Zero calibration first and perform Span calibration following zero calibration completion. Calibration menu structure is given in below diagram:

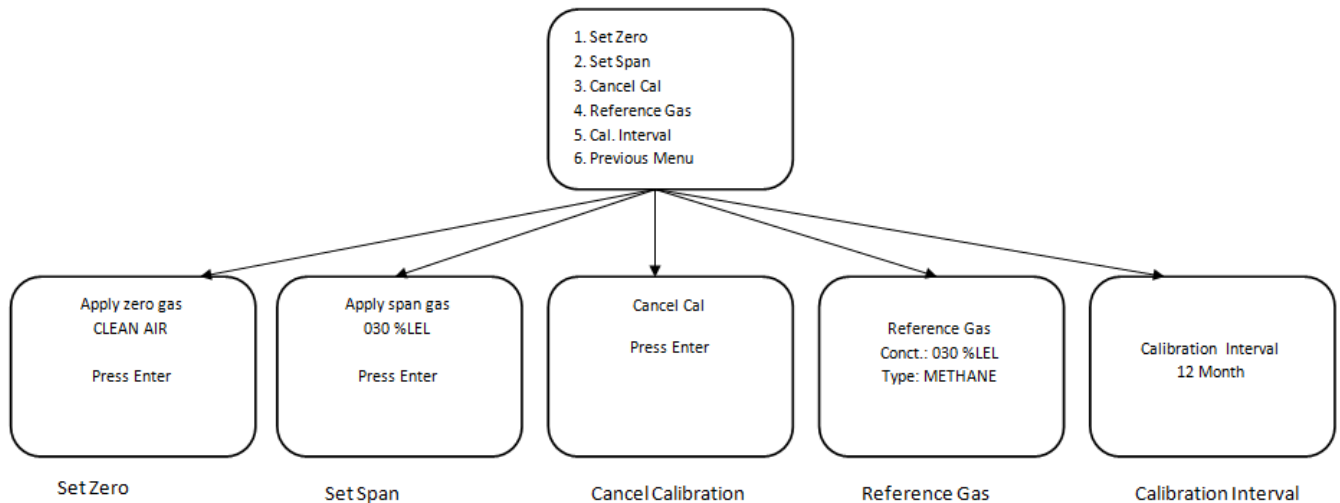
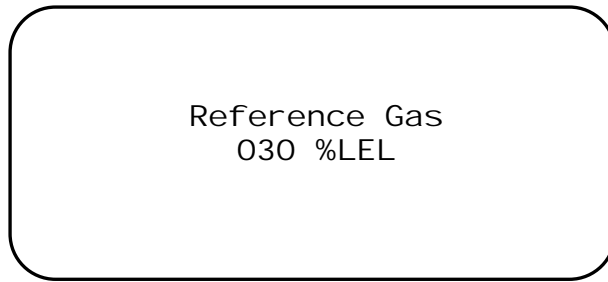

Diagram18: Calibration menu structure

Set Reference Gas details

During calibration technician should use a certificated specific gas. The details of the gas should be entered before starting the calibration. Otherwise detector program will use default values entered at factory. If the calibration gas is different than default gas specifications the calibration will fail or will be wrong. Select fourth item 'Reference Gas' on calibration menu to set details of the gas you will use during calibration. The default value is % 30 LEL will be displayed:



The first digit will start blinking on screen. You can change the value of each digit with up and down keys. Once set, confirm value with Enter key and move to the next digit.

Set Calibration Cycle

Prosense recommends performing calibration with six months period. Hence this default value is set to detector in factory. Detector will be faulted when calibration period expire. If user wants to use different calibration period this should be set via using the option "Cal Cycle" on calibration menu. Select "Cal Cycle" and press Enter. A new screen will display to allow you set your calibration period:

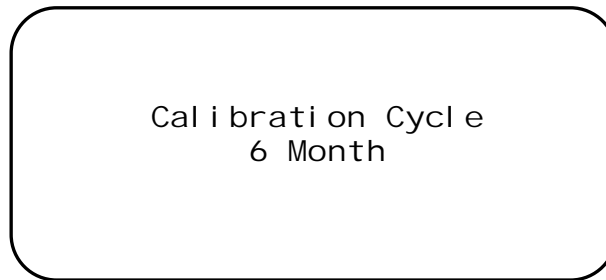

The number will be blinking. Value can be adjusted using up and down keys. Once set press Enter key to confirm and return back to calibration menu.

Zero Calibration

Select Set Zero option on calibration menu and press Enter key to start zero calibration. Program will request a confirmation to start zero calibration:



When entered it will start countdown from 60 to 0:

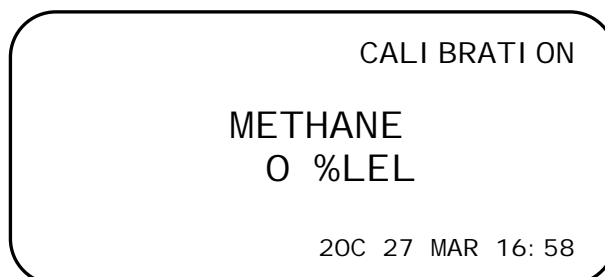

During this time you should apply necessary gas for zero level. For catalytic, pellistor and electrochemical sensors use clean air gas, for infrared sensors use N2 gas. For more details contact Prosense. Detector will automatically perform zero calibration while gas applied to sensor during this period.

Span Calibration

To perform Span calibration Select Set Span option on calibration menu and press Enter key to start span calibration. At same time prepare the span gas cylinder and regulator; mount the calibration adaptor to the sensor head and apply gas to the detector. Program will request a confirmation to start Span calibration:



After pressing Enter key screen will again show countdown from 60:

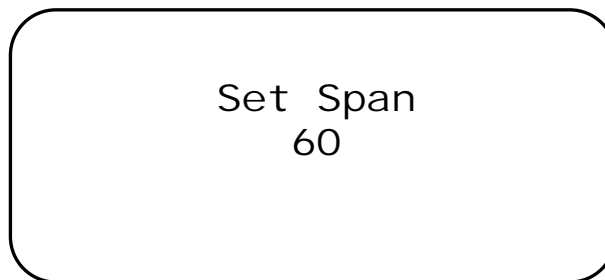

During this period gas should be applied to sensor. Detector will automatically set span level. When countdown completed it will return to monitoring screen via exiting from menu. If you try to enter menu detector will ask password again. The alarms will be activated as gas applied to detector and detector exit from calibration mode.

Cancel Calibration

Calibration can be cancelled anytime during calibration operation. If user thinks something done wrong by mistake, should select "Cancel Cal" option on calibration menu. Detector will ask confirmation to cancel:

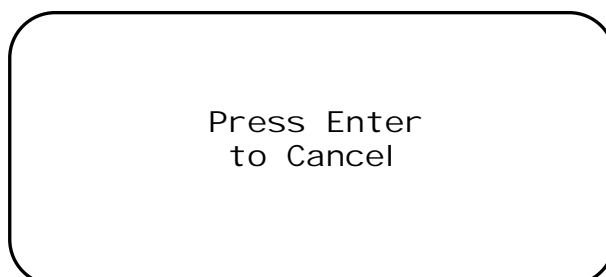

Press Enter key to cancel calibration operation.

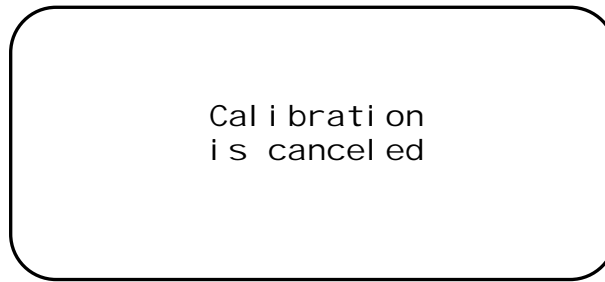

Detector will erase the values recorded during calibration steps and uses previously recorded calibration levels.

Maintenance

Proactive maintenance:

All gas detectors including both for flammable and toxic gases should have to pass a functional test and calibration every three to twelve months according to EN 60079-29-2 industrial standards. The test results and calibration reports should be recorded in maintenance books.

Operational Life:

Catalytic flammable gas sensor made by using the pellistors that suffer from a loss of sensitivity when in the presence of poisons or inhibitors, e.g. silicones, sulphides, chlorine, lead or halogenated hydrocarbons. The pellistors are poison resistant to maximize the operational life of the Catalytic flammable sensor. A typical operating life, subject to the presence of poisons/inhibitors is 48-60 months. The infrared flammable gas sensor is not affected by the mentioned poisons and has a longer life span.

Typical life of a toxic gas sensor which made by electrochemical component is dependent on the application, frequency and amount of gas exposure. Under normal conditions (visual inspection in 3 months period and test/recalibration in 6 months period), the Prosense Oxygen and other toxic sensors have an expected life equal to or greater than 24 months.

Servicing

Important: All replacement actions (sensor, sinter, and sensor head) shall be done by Prosense trained service personnel as servicing needs special steps that should be performed according to device technical characteristics.

Battery

Detector main board includes a battery (3.3V, 10mA). The purpose is to keep event logs and recorded values during the life time of the detector and prevent data loss in case of power outage. Battery does not have any function on performing detector functions and not providing power to detector.



Do not remove or replace the battery!

Sensor replacement:

The Flammable Catalytic and Toxic ECC cells that are used with the Prosense Sensor Head have limited serviceable parts. Detector must be diagnosed by service personnel when they have reached the end of their operational life or faced with a fault to follow correct procedure.

Pellistor sensor replacement:

Due to current technical design pellistor sensors are not replaceable in the field. The whole sensor head assembly must be replaced once the pelistor sensor has reached end of its life or in case of any failure.

Electrochemical sensor:

The electrochemical sensors are mounted to sensor electronic module inside the sensor head and it is possible to perform replacement in the field. Once replacement sensor on hand follow the steps given below:

- 1- Power-off the detector via disconnecting power cable from control panel or supply
- 2- Use allen key nr3 to loosen locking grub screw on sensor head
- 3- Remove the sensor head cap
- 4- Check the sinter and if it blocks the air ventilation replace the sinter via steps given in "Sinter Replacement" section.
- 5- Remove electrochemical sensor from sensor module.
- 6- Check sensor electronic module. Some EEC sensors might leak to the sensor PCB and create unrepairable hazard on PCB. The whole sensor head must be replaced if there is any chemical leakage on sensor PCB.
- 7- Install the new sensor in to sensor PCB.
- 8- Install the sensor head cab and fix the locking grub screw.
- 9- Power-on the detector and wait at least 4 hours
- 10- Perform full calibration.

Infrared Sensor:

The NDIR sensors are mounted to sensor electronic module (sensor PCB) inside the sensor head and it is possible to perform replacement in the field. Once replacement sensor on hand follow the steps given below:

- 1- Power-off the detector via disconnecting power cable from control panel or supply
- 2- Use allen key nr3 to loosen locking grub screw on sensor head
- 3- Remove the sensor head cap
- 4- Check the sinter and if it blocks the air ventilation replace the sinter via steps given in "Sinter Replacement" section.
- 5- Remove NDIR sensor from sensor module.
- 6- Install the new sensor into sensor PCB.
- 7- Install the sensor head cab and fix the locking grub screw.

- 8- Power-on the detector and wait at least 30 minutes
- 9- Perform full calibration.

Sensor PCB replacement:

Due to current technical design restrictions sensors PCBs are not replaceable in the field. The whole sensor head assembly must be replaced once the sensor PCB damaged or in case of any failure.

Sinter replacement:

Due to environmental conditions the metal filter - sinter at sensor head might lost permeability that could negative impact on sensor performance. For example if the installation includes cement or similar dust the sinter would be block the air/gas entry to sensor. The sinter should be checked visually and replaced if necessary. The sinter is located inside the sensor head cap and sensor head cap must be replaced when sinter needs replacement. To replace sinter please check diagram-2 and follow the below procedure:

- 1- Power off the detector via disconnecting power cable from control panel or supply
- 2- Loosen the locking grub screw via allen key nr3
- 3- Unscrew the sensor head cap that holds the dirty sinter
- 4- Remove the sinter holder via using two holes on it
- 5- Remove the old sinter
- 6- Install new sinter to its location, make sure sinter located correctly to designed area
- 7- Install sinter holder and fix completely to hold sinter to go back
- 8- Screw the sensor head cap including the clean sinter
- 9- Fix the Locking grub screw

Sensor head replacement:

Prosense sensor head is a separate part that can be replaced. The sensor head includes integrated sensor, electronic device and sinter in it. PQ series sensor head is pre-calibrated and will start function immediately following the replacement. To replace sensor head:

- 1- Power-Off the detector via disconnecting power cable from control panel or supply
- 2- Open the detector cover
- 3- Disconnect sensor cables from the detector main board
- 4- Remove the sensor head from the body via using Nr 38 wrench key.
- 5- Install sensor head
- 6- Sensor head must be fixed to enclosure with 20Nm toque
- 7- Connect the sensor cables to detector main board
- 8- Close the detector cover
- 9- Power-On Prosense detector
- 10- Leave detector working at least 4 hours in clean air environment
- 11- Check detector calibration.

Detector Transmitter board replacement:

Prosense detector transmitter is the main logic board including all definitions and configuration. Hence it is necessary to perform reconfiguration in case of replacement. Hence the spare part must be ordered by giving the serial number of the detector. The replacement should be done via following steps:

- 1- Power-Off the detector via disconnecting power cable from control panel or supply
- 2- Open the detector cover
- 3- Remove display module from the mounting rails (PQN does not have display module)
- 4- Disconnect sensor, display, power and other external interface cables from the detector main board (see diagram-11)
- 5- Remove the screws mounting the board to enclosure.
- 6- Remove the board
- 7- Install new board and fix via putting screws
- 8- Install sensor and display cables
- 9- Install power and other external interface cables
- 10- Power-on detector and check the LEDs according to steps given in “Commissioning” section
- 11- Leave detector working at least 4 hours in clean air environment
- 12- Check detector calibration.

PQD Detector Display Module replacement:

Prosense PQD display board is a replaceable part. The replacement should be done via following steps:

- 1- Power-Off the detector via disconnecting power cable from control panel or supply
- 2- Open the detector cover
- 3- Remove display module from the mounting rails
- 4- Disconnect display cable from main board (see diagram-11). The display board fixed to the display board and should be disconnected from the socket on main board to remove display module.
- 5- Connect new display boards connector to main board.
- 6- Install display board to mounting rails
- 7- Power-on detector and check the LEDs according to steps given in “Commissioning” section
- 8- Check detector settings and adjust if necessary.

Detector Relay Module replacement:

Prosense PQD relay module is a replaceable part. The replacement should be done via following steps:

- 1- Power-Off the detector via disconnecting power cable from control panel or supply
- 2- Open the detector cover
- 3- Remove display module from the mounting rails (PQN does not have display module)
- 4- Disconnect relay module output connections.
- 5- Remove display module mounting rails that is fixed on top of relay module mounting rails. If there is no display relay module is fixed with screws, remove the screws.
- 6- Remove relay module.
- 7- Install relay module while taking care to connectors directly on main board socket. The main board battery must be relax on the empty location of relay module.
- 8- If there is no display module (PQN) fix the relay module via using screws.
- 9- Fix the display module mounting rails on top of relay module mounting rails. These should fix the relay module as well.
- 10- Perform any adjustment necessary about alarm levels and relay operating modes via using jumper on relay module.
- 11- Reconnect relay module output connections.
- 12- Install display module from the mounting rails (PQN does not have display module)
- 13- Power-on detector and check the LEDs according to steps given in “Commissioning” section
- 14- Check detector settings and adjust if necessary.

Status Codes:

Fault Code	Fault Text	Fault Description
0x00	NO FAULT	OK
0x10	SENSOR ERROR	Sensor is in fault condition
0x11	NOT CONNECTED	Sensor is not connected or one-wire communication doesnot work.
0x12	SIGNAL OUT RANGE	Sensor signal is out of range
0x13	TEMPERATURE ERR	Temperature is out of range
0x14	SENSOR_TYPE ERR	Sensor type definiton read from sensor module does not match the recorded configuration value
0x15	IR_LAMP_FRQ_ERR	IR Timer error
0x16	SENSOR REG ERR	Sensor power voltage error
0x17	IR LAMP REG ERR	IR sensor lamp regulator is in fault condition and does not generate lamp feeding signal
0x18	SENSOR SWITCHED OFF	Pellistor sensor power off due to overrange for sensor protection
0x19	SENSOR REGULATOR	Sensor regulator error, sensor power is not in defined range
0x1A	SENSOR MODEL ERR	Sensor model read from sensor module does not match the recorded configuration value
0x1B	SENSOR DATA CRC ERR	Sensor Data corruption detected
0x1C	NEGATIVE DRIFT	Sensor signal is below defined minimum value
0x20	ADC ERR	ADC circuit is not functioning correctly
0x21	INT ADC1 ERR	Internal ADC1 signal level is not correct
0x30	CURRENT OUTPUT ERR	Detector is not generating analogue output signal
0x31	DAC OUTPUT ERROR	MCU DAC output signal level is out of range
0x32	LINE OUTPUT OPEN	Analogue output is not connected
0x33	LINE OUTPUT SHORT	Analogue output is shorted
0x40	SUPPLY VOL ERROR	Power input is above maximum level
0x41	LOW SUPPLY VOLTAGE	Power input is below minimum level
0x50	PRG RAM ERROR	RAM fault detected
0x51	RAM TEST FAILURE	RAM test is failed
0x52	STACK OVERFLOW ERR	Stack Overflow Error
0x60	PRG FLASH ERR	Flash error detected
0x61	FLASH CRC ERR	Flash data corrupt
0x62	CRC INIT ERR	CRC calculation error
0x63	XTRM STNGS CRC ERR	Main board parameter corruption
0x71	SETTINGS CRC ERR	Parameter corruption
0x72	ONE WIRE ERR	Main board and sensor board communication error
0x81	SENSOR CALIB DUE	Defined calibration period is passed, calibraton needed
0x82	BUMP TEST DUE	Defined bump test period is passed, bump test needed
0x90	BATTERY ERROR	Battery is in fault condition
0x91	BATTERY VOLTAGE LOW	Battery level is low
0x92	NO BATTERY DETECTED	No battery is installed
0xa1	DSP COMMM ERR	Display communication failure
0xa2	RS485 COMMM ERR	RS485 communication failure

Fault Code	Fault Text	Fault Description
0xB0	RELAY CARD ERR	Relay module communication error
0xB1	FAULT RELAY ERR	Fault relay is not functioning
0xB2	ALARM_1 RELAY ERR	Alarm1 relay is not functioning
0xB3	ALARM_2 RELAY ERR	Alarm2 relay is not functioning

Spare Parts

Product Code	Description
PY-05S-05	Pellistor Sensor Head, 0-100 %LEL
PY-05S-03	Infrared Sensor Head, 0-100 %LEL
PY-05S-36	Hydrogen Sensor Head, 0-500 ppm
PY-05S-36B	Hydrogen Sensor Head, 0-1000 ppm
PY-05S-36C	Hydrogen Sensor Head, 0-2000 ppm
PY-05S-44	Carbon monoxide Sensor Head, 0-300 ppm
PY-05S-44B	Carbon monoxide Sensor Head, 0-500 ppm
PY-05S-44C	Carbon monoxide Sensor Head, 0-1000 ppm
PY-05S-48	Ammonia Sensor Head, 0-100 ppm
PY-05S-48B	Ammonia Sensor Head, 0-1000 ppm
PY-05S-60	Acetylene Sensor Head, 0-100 %LEL
PY-05S-62	Ethylene Oxide(ETO) Sensor Head, 0-20 ppm
PY-05S-62B	Ethylene Oxide(ETO) Sensor Head, 0-100 ppm, 1 Year
PY-05S-64	Hydrogen Sulfide(H ₂ S) Sensor Head, 0-100 ppm
PY-05S-64B	Hydrogen Sulfide(H ₂ S) Sensor Head, 0-500 ppm
PY-05S-65	Oxygen Sensor Head, 0-25% vol
PY-05S-66	Sulfide Dioxide Sensor Head, 0-10 ppm
PY-05S-67	Nitric Oxide Sensor Head, 0-250 ppm
PY-05S-68	Nitrogen Dioxide Sensor Head, 0-30 ppm
PY-05S-69	Chlorine Sensor Head, 0-10 ppm
PY-05S-71	Carbondioxide Sensor Head, 0-5000 ppm
PY-05S-71B	Carbondioxide Sensor Head, 0-5% Vol
PY-05S-72	Freon Sensor Head, 0-2000 ppm
PY-05S-74	Formaldehyde Sensor Head, 0-10 ppm
PY-05K-N	PQN Enclosure
PY-05K-D	PQD Enclosure
UPY-05T	PQ Transmitter
UPY-05T-D	PQD OLED Display Assembly

UPY-05S-03	PQ Series Infrared Sensor, 0-100 %LEL
UPY-05S-05	PQ Series Pellistor Sensor, 0-100 %LEL
UPY-05S-44	PQ Series Carbon Monoxide Sensor, 0-300 ppm
UPY-05S-44B	PQ Series Carbon Monoxide Sensor, 0-500 ppm
UPY-05S-44C	PQ Series Carbon Monoxide Sensor, 0-1000 ppm
UPY-05S-48	PQ Series Ammonia Sensor, 0-100 ppm
UPY-05S-48B	PQ Series Ammonia Sensor, 0-100 ppm
UPY-05S-60	PQ Series Acetylene Pellistor Sensor, 0-100 %LEL
UPY-05S-62	PQ Series Eto Sensor, 0-20 ppm
UPY-05S-62B	PQ Series Eto Sensor, 0-100 ppm
UPY-05S-64	PQ Series Hydrogen Sulfide Sensor, 0-100 ppm
UPY-05S-64B	PQ Series Hydrogen Sulfide Sensor, 0-500 ppm
UPY-05S-65	PQ Series Oxygene Sensor, 0-25% Vol
UPY-05S-66	PQ Series Sulfur Dioxide Sensor, 0-10 ppm
UPY-05S-67	PQ Series Nitric Oxide Sensor , 0-250 ppm
UPY-05S-68	PQ Series Nitrogen Dioxide Sensor, 0-30 ppm
UPY-05S-69	PQ Series Chlorine Dioxide Sensor, 0-10 ppm
UPY-05S-71	PQ Series Carbon Dioxide Sensor, 0-5000 ppm
UPY-05S-71B	PQ Series Carbon Dioxide Sensor, 0-5% Vol
UPY-05S-72	PQ Series Refrigerant (Freon) Sensor, 0-2000 ppm
UPY-05S-74	PQ Series Formaldehyde Sensor, 0-10 ppm
UPY-05S-75	PQ Series Hydrogen Cyanide Sensor, 0-25 ppm
UPY-05S-76	PQ Series Hydrogen Peroxide Sensor, 0-300 ppm
UPY-05S-80	PQ Series VOC (PID) Sensor, 0-100 ppm
UPY-05S-80B	PQ Series VOC (PID Sensor, 0-1000 ppm
UPY-SH30	SH30 Sensor Head
UPY-SIN	Sinter for SH30

General specification

Use:

3-wire, 4-20mA or 4-wire RS485, gas detector transmitter for use with directly installed flammable and toxic gas sensors. For the protection of personnel and plant from flammable and toxic gas hazards.

Electrical Specifications:

Input Voltage Range	12 to 24VDC (24VDC nominal)
Max Power Consumption	Max 4 Watts. at 24VDC
Current output	4-20mA
1.0 - 3.0 mA (adjustable)	Fault
2.0 - 3.0 mA (adjustable)	Inhibit (during configuration/warming)
1.0 - 3.0 mA (adjustable)	Calibration mode
4.0 mA to 20.0 mA	Normal gas measurement
21.0 - 22.0 mA (adjustable)	Maximum over range
Terminals	3 x screw terminals suitable for wire diameter 0.5 mm ² to 2.5 mm ² (20AWG to 13AWG). 2 x screw terminals suitable for wire diameter 0.5 mm ² to 2.5 mm ² (20AWG to 13AWG) for RS485 digital output
Relays	3 x (1A 30VDC, 0.5A 125VAC, 0.3A 80VDC). Selectable normally open or normally closed (switch) and de-energized.
Communication	RS485, Modbus RTU

Table 13: Electrical specifications

Detector Body Specifications:

Material	Epoxy painted aluminium alloy junction box, 316 - Stainless Steel Sensor Head
Weight	Aluminium Alloy : 2.1kg - PQD (with Sensor Head) 1.85kg - PQN (with Sensor Head)
Mounting	Wall mounting
Entries	3 x ½ NPT field cable entries, ¼ NPT sensor entry *

* Entry specks may vary depending of the body type, please check Table-1

Table 14: Detector body specifications

Environmental:

IP Rating	IP65 in accordance with EN60529:1992
Operating Temperature	-40°C to +70°C / -40°F to +158°F – For explosion protection -20°C to +60°C / -04°F to +140°F – For performance
Operating Humidity	Continuous 20-90%RH (non condensing)
Operating Pressure	80-120kPa
Storage Conditions	-30°C to +70°C (-22°F to +158°F)

Table 15: Environmental specifications

SAFETY INSTRUCTIONS FOR HAZARDOUS AREA INSTALLATION

Prosense PQ series gas detectors are projected and built according to ATEX Directive 2014/34/EU with reference to standard EN 60079-0, EN 60079-1, EN 60079-29-1. "ATEX", by the French "ATmosphere EXplosible", provides the technical requirements to be applied to equipment intended for use in potentially explosive atmospheres. The scope of directive is to remove technical barriers to trade between Member States of the European Community. The Prosense PQ series gas detectors must be installed and maintenance according to the suitable standards for electrical application in potentially explosive atmospheres (example: EN 60079-14, EN 60079-17 or other national standards).

Read this instruction first and keep this instruction manual always available.

The following instructions apply to equipment covered by ATEX certificate number:

1. Prosense PQ series gas detectors may be installed in hazardous area with flammable gases, vapours, and mist, group II, category 2G, maximum superficial permissible temperature 70°C.

Device category 2G, Identification II 2G

Ex db IIC T6 Gb (Tamb = -40°C : +70°C) – For explosion protection

(Tamb = -20°C : +60°C) – For performance

It means:  (European Community logo for ATEX applications) – group II (potentially explosive atmospheres – surface application – OTHER than mines)

Category 2G (G => Gas) – Zone 1 and Zone 2

Ex db => protection mode: explosion proof enclosure

IIC => define kind of gases

T6 => Temperature class -- Maximum allowable surface temperature.

IP 65 => Mechanical protection degree – protection against solid, dust and liquid.

2. Suitably trained personnel shall carry out installation in accordance with applicable code practice.

3. The electrical devices must be grounded using their grounding connections. The grounding connection must be ATEX certified, suitable for the application required, substances, maximum superficial temperature, and ambient temperature.

4. The user should guarantee periodical cleaning of the places where dust can store to avoid the piling up to 5 mm.

5. The user should not repair this equipment.

6. The user should guarantee the keeping of the safety characteristic of the device after maintenance or repairing.

7. If the equipment is likely to come into contact with aggressive substances, it is responsibility of the user to take suitable precautions that prevent it from being adversely affected, thus ensuring that the type of protection is not compromised.

Aggressive substances: example Acids, liquid, gases with can affected metals

8. To guarantee the respect of the protection degree cable glands, blanking elements and thread adapters shall be certified Ex components according to protection “db” and a blanking element shall not be used with an adapter.

9. Sinter replacement shall be done by an approved technical service personal according to PQ Series user manual “Sinter replacement” procedure (PRS-UM-PQ-EN-Rev.03-02.2019 page 45).

10. O-ring is made of Silicone and continuous operating temperature is -50C to 105C

11. If temperature exceeds 70°C at entry or 80°C at branching point use suitably rated cable and cable glands or conductors in conduit.

12. Thickness of outer painting is between 40 µm – 180 µm.

13. Maximum power consumption of the detector with optional boards installed is $P_{max}=4W$ where $I_{max}=335mA$ and $V_{max}=24VDC$.

14. All electrical connections should be made in accordance with any relevant local or national legislation, standards or codes of practice. Prosense detectors can operate between 12 - 24 VDC. The connection, grounding, cabling details are explained in this guide at relevant sections

Certificate



1 EU - Type Examination Certificate

2 Equipment intended for use in Potentially Explosive Atmospheres Directive 2014/34/EU

3 Certificate Number: ExVeritas 18 ATEX 0371X Issue: 1

4 Equipment: PQ Series Gas Detectors

5 Manufacturer: Prosense Teknoloji San Ltd Şti

6 Address: Yukan Mah.
Harman Sok No:42,
34860, Kartal
Istanbul, Turkey

7 This equipment and any acceptable variation thereto are specified in the schedule to this certificate and the documents therein referred to.

8 ExVeritas, Notified Body number 2565 in accordance with Article 17 of the Council Directive 2014/34/EU of 26 February 2014, certifies that this equipment or protective system has been found to comply with the Essential Health and Safety Requirements relating to design and construction of equipment and protective systems for use in potentially explosive atmospheres given in Annex I to the Directive

9 Compliance with the applicable Essential Health and Safety Requirements has been assured by compliance with the following Standards and section 18 of this certificate:

EN 60079-0: 2018 EN 60079-1: 2014

10 If the sign "X" is placed after the certificate number, it indicates that the equipment is subject to special conditions for safe use specified in the schedule to this certificate.

11 This EU-Type Examination Certificate relates only to the design, construction, examination and tests of the specified equipment or protective system in accordance to the Directive 2014/34/EU. Further requirements of the Directive apply to the manufacturing process and supply of this equipment or protective system. These are not covered by this certificate.

12 The marking of the equipment shall include the following:

 II 2G
I M2

Ex db IIC T6 Gb
Ex db I Mb

Tamb -40°C to + 70°C



No. 8613

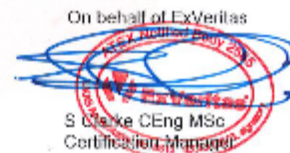

This certificate may only be reproduced in its entirety and without any change, schedule included.
The certificate is only valid when it carries an original signature.
For help or assistance relating to this certificate, contact info@exveritas.com.
ExVeritas, Units 18-16, Abenbury Way, Wrexham Industrial Estate, Wrexham, United Kingdom LL13 8UZ.
ExVeritas® is a registered trademark, unauthorised use will lead to prosecution.



Schedule

13 Description of Equipment or Protective System

The PQ Series Gas Detectors are constructed from a threaded aluminium or 316L stainless steel Junction Box that can be fitted with either a solid (PON) or glassed windowed (PQD) cover. There are four optional entries for the fitting of power and data cables and a gas sensing head. Thread forms can be chosen between ½” ½” NPT and M20 for the cable entries and ¾” NPT for the gas sensing head.

The PQ Gas Detector is intended to detect the presence of flammable and toxic gases in air or oxygen. They are powered by 12-24 Vdc providing a 4-20 mA, RS485 or dry contacts with optional relay board signal proportional to the respective gas concentration. The Junction Boxes house the electronics assemblies, a display and various status indicators viewed through the glass window and optional relay board. Complete codes and characteristics of detectors are reported in the manual. The identification code is reported on the label fixed on the sensor and on the enclosure.

Rating: 12 to 24Vdc, 4Watt (max)

13.1 Issue 1

The following changes are incorporated in issue 1 of the certificate

- Inclusion for Group I, mining with Stainless Steel construction
- Change of low Temp from -20°C to -40°C
- Correction of typographical error to revision status of drawing PQ TD6 for issue 0, originally detailed as Rev 1.1, now corrected to Rev 1.3.

14 Descriptive Documents

14.1 Associated Report and Certificate History:

Report Number	Cert Issue Date	Issue	Comment
R14677A/1	23 Oct 2010	0	Initial issue of the Print Certificate
R14677A/2	30 Apr 2018	1	First variation, see 13.1 for details

14.2 Compliance Drawings:

Issue 0

Title:	Drawing No:	Sheets:	Rev. Level:	Date:
Overall Drawing	PQ 1D1	1 of 1	1.1	4.10.2018
PQD Sight Glass	PQ 1D2	1 of 1	1.1	4.10.2018
PQN Junction Box cover	PQ TD3	1 of 1	1.1	4.10.2018
PQD Junction Box Cover	PQ TD4	1 of 1	1.1	4.10.2018
PQD Sight Glass cover disk	PQ TD5	1 of 1	1.1	4.10.2018
Junction Box	PQ TD6	1 of 1	1.3	4.10.2018
PQ Series product Label	TF3	1 of 1	01	11.10.2010

Certificate: ExVeritas 18 ATEX 037 IX - Issue 1

This certificate may only be reproduced in its entirety and without any change, schedule included.
 For help or assistance relating to this certificate, contact info@exveritas.com.
 ExVeritas, Units 15-16, Abernethy Way, Wrexham Industrial Estate, Wrexham, United Kingdom LL13 9JZ.
 ExVeritas® is a registered trademark, unauthorised use will lead to prosecution.



Schedule

Issue 1

Title	Drawing No.	Sheets	Rev. Level	Date
Junction Box	PQ TD6	1 of 1	1.1	12.04.2010
PQ Series product Label	TF3	1 of 1	01	11.10.2018
PQ Series product Label	1F3	1 of 1	02	04.04.2019
PQ TD6 Junction Box SS 1	PQ TD6 SS 1	1 of 1	1.0	19.02.2019
PQ TD6 Junction Box SS 2	PQ TD6 SS 2	1 of 1	1.0	19.02.2019
PQ TD6 PCN Junction Box Cover SS	PQ TD6 SS	1 of 1	1.0	19.02.2019

15 Conditions of Certification

15.1 Special Conditions for Safe Use

- Flame paths must not be repaired
- Equipment must only be filled with suitably certified sensor head to maintain integrity of the Ex d enclosure wall.

15.2 Conditions for Use/Conditions of Manufacture

- Equipment must only be filled with suitably certified sensor head to maintain integrity of the Ex d enclosure wall.

16 Essential Health and Safety Requirements

Essential Health and Safety Requirements are addressed by the standards listed in section 9 and where required the report listed in section 14.1

The manufacturer shall inform the Notified Body of any modifications to the design of the product described by this schedule.

Certificate: ExVeritas 18 ATEX 0371X Issue 1

This certificate may only be reproduced in its entirety and without any change, schedule included.
For help or assistance relating to this certificate, contact info@exveritas.com.
ExVeritas, Units 13-15, Gombury Way, Wrexham Industrial Estate, Wrexham, United Kingdom LL13 9JZ.
ExVeritas® is a registered trademark. Unauthorised use will lead to prosecution.

Declaration



Manufacturer Declaration of Conformity



Prosense Teknoloji San Ltd. Şti declares the PQ series products to be in accordance with the following standards and directives.

Name and address of Manufacturer: **Prosense Teknoloji San Ltd Şti**
Cumhuriyet Mah. Mermer Sok No:16
34876 - Kartal – İstanbul – Türkiye

Description of Devices: PQ Series (PQD and PQN) Fixed Type Gas Detectors

Ex Designation:  II 2G Ex db IIC T6 Gb

Applied Harmonized international standards:

EN 60079-0:2018 Equipment – General requirements
EN 60079-1:2014 Equipment protection by flameproof enclosures 'd'
EN 60079-29-1: 2016 Gas detectors – Performance requirements of detectors for flammable gases
EN 50270:2015 Electromagnetic compatibility - Electrical apparatus for the detection and measurement of combustible gases, toxic gases and oxygen
EN 50271:2018 Electrical apparatus for the detection and measurement of combustible gases, toxic gases or oxygen - Requirements and tests for apparatus using software and/or digital technologie

Applied European Directives:

2014/34/EU ATEX Directive
2014/30/EU Electromagnetic Compatibility (EMC) Directive

Each PQ (PQN and PQD) Series gas detector device which the Production Quality Assurance procedures and Type Examination procedures have been applied has been shown to conform to an approved Type and to the applicable classification rules and essential principles before being supplied. This declaration is being made on the basis of the following certificates:

Production Quality Assurance Certificate: ExVeritas 18PQAN0072

Type Examination Certificate: ExVeritas ATEX 0371
IECEx ExVeritas 18.0021X

Type Examination Certificate: FTZU 19E002

Authorised Signatory: First Celep
Production Manager

Date: 26.02.2020

Warranty statement

All products are designed and manufactured to the latest internationally recognized standards by Prosense Technology under a Quality Management system that is certified to ISO 9001. As such Prosense Technology warrants its products against defective parts and workmanship and will repair or (at its option) replace any instruments which are or may become defective under proper use within 12 months from date of commissioning by an approved Prosense Technology representative or 18 months from date of shipment from Prosense Technology, whichever is the sooner. This warranty does not cover disposable batteries or damage caused by accident, abuse, abnormal operating conditions or poisoning of sensor.

Defective goods must be returned to Prosense Technology premises accompanied by a detailed description of any issue. Where return of goods is not practicable Prosense Technology reserves the right to charge for any site attendance where any fault is not found with the equipment. Prosense Technology shall not be liable for any loss or damage whatsoever or howsoever occasioned which may be a direct or indirect result of the use or operation of the Contract Goods by the Buyer or any Party.

This warranty covers instrument and parts sold to the Buyer only by authorized distributors, dealers and representatives as appointed by Prosense Technology. The warranties set out in this clause are not pro rata, i.e. the initial warranty period is not extended by virtue of any works carried out there under.

In no event will Prosense Technology be liable for any incidental damages, consequential damages, special damages, punitive damages, statutory damages, indirect damages, loss of profits, loss of revenues, or loss of use, even if informed of the possibility of such damages. Prosense Technology's liability for any claims arising out of or related to this product will in no case exceed the order value. To the extent permitted by applicable law, these limitations and exclusions will apply regardless of whether liability arises from breach of contract, warranty, tort (including but not limited to negligence), by operation of law, or otherwise.