

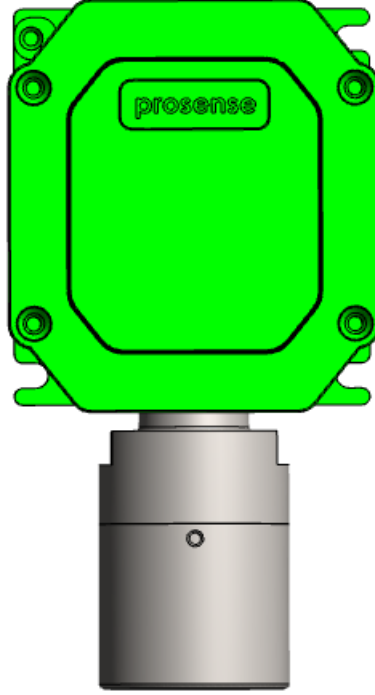

PROSENSE PC3 Series Gas Detectors Installation and User Manual



**Prosense Teknoloji San. Ltd. Şti.
Cumhuriyet Mah. Mermer Sok. No:16 Kartal/İstanbul TÜRKİYE
Tel: +(90) 216 306 77 88 Faks: +(90)216 473 81 29
www.prosense.com.tr**

WARNING!

This manual must be carefully read by all persons who have or will have the responsibility for installing, using or servicing this product.

Like any equipment, this product will perform as designed only if installed, used and serviced in accordance with the manufacturer's instructions. Otherwise, it could fail to perform as designed and persons who rely on this product for their safety could suffer severe personal injury or death.

The warranties made by Prosense with respect to this product are voided if the product is not installed, used and serviced in accordance with the instructions in this user guide. Please protect yourself and other by following them.

Important Remark

The detector has been factory-tested and calibrated before delivery. The commissioning has to be terminated by a function test of the complete gas detection system.

Contents

- For Your Safety 4
 - Strictly Follow the Instructions for Use 4
 - Maintenance 4
 - Use in Areas Subject To Explosion Hazards 4
 - Liability for Proper Function or Damage..... 4
 - Intended Use 4
- Introduction 6
- Detector Body 7
- Sensor Head: 7
- Installation: 7
- Mounting the Detector: 8
- Electrical Connections 9
- Cabling 11
- Detector Grounding 12
- Default Configuration..... 13
- Detector Configuration 13
- 4-20 mA Output: 14
- RS485 Serial MODBUS Output:..... 14
- Detector Relay Module: 16
- System Status 17
- First Time Switch on (Commissioning)..... 18
- Calibration..... 18
 - Zero Calibration..... 19
 - Span Calibration 19
- Maintenance 20
 - Proactive Maintenance: 20
 - Operational Life:..... 20
 - Sensor Replacement:..... 21
 - Sinter Replacement:..... 21
 - Sensor Head Replacement: 21
- General Specification 22
- Certification..... 23
- Warranty Statement 24

For Your Safety

Ensure that this Operating Manual is read and understood **BEFORE** installing / operating / maintaining the equipment. Pay particular attention to Warnings and Cautions. All document Warnings are listed here and repeated where appropriate at the start of the relevant chapter(s) of this Operating Manual. Cautions appear in the sections/sub-sections of the document where they apply.

Strictly Follow the Instructions for Use

Any use of the detectors requires full understanding and strict observation of these instructions. The detector is only to be used for purposes specified here.

Maintenance

It is recommended to obtain a service contract Prosense to carry out all repairs. Only authentic Prosense spare parts should be used for maintenance. Please check “Maintenance” section for more details.

Use in Areas Subject To Explosion Hazards

Equipment or components which are used in potentially explosive atmospheres and have been tested and approved according to international or European regulations may be used only under the conditions specified here. Modifications of components or the use of faulty or incomplete parts are not permitted. In case of repairs of equipment or components, the national regulations must be observed.

Liability for Proper Function or Damage

The liability for the proper function of the detector is irrevocably transferred to the owner or operator to the extent that the detector is serviced or repaired by personnel not employed or authorized by Prosense or if the sensing head is used in a manner not conforming to its intended use. Prosense cannot be held responsible for damage caused by non-compliance with the recommendations given above. The warranty and liability provisions of the terms of sale and delivery of Prosense are likewise not modified by the recommendations given above.

Intended Use

The PC3 series detectors are intended to be used for stationary, continuous monitoring for combustible and toxic gas/air or vapour/air mixtures and oxygen under atmospheric conditions. According to the ATEX Directive 2014/34/EU and IECEx rules the device category is III. Thus this detector is suitable to be operated in Zone 2.

Hazardous area classifications:

Zone 0: An area classified as Zone 0 will have ignitable concentrations of flammable gases, vapours or liquids either continuously present or present for long periods of time under normal operating conditions

Zone 1: An area classified as Zone 1 is likely to have ignitable concentrations of flammable gases, vapours or liquids present under normal operating conditions. Flameproof (Ex db) detectors are suitable for use in Zone 1.

Zone 2: An area classified as Zone 2 is not likely to have ignitable concentrations of flammable gases, vapours or liquids present under normal operating conditions. PC3 Series detectors are suitable for use in Zone 2.

Not to be used in oxygen enriched atmospheres.

In conjunction with the central controllers Prosense detectors with preadjusted alarm thresholds audible and visible alarm devices or automatic countermeasures can be activated before the detected gases or vapours can form dangerous flammable or toxic mixtures with air.

Please be alerted in following special conditions may have impact on measuring function due to the nature of measuring method:

1. Very High Gas Concentrations

The measuring method based on heat produced by reaction on the catalytic oxidation of a flammable gas when pellistor sensor used. In case of high gas concentrations there is not enough oxygen in the sensor to perform oxidation process correctly. Hence the measuring signal decreases at high gas concentrations and even can lead to measuring signal within the measuring range again. In this case do not reset latching alarms without having ensured a safe condition by means of an independent gas concentrations measurement.

2. Minimum Oxygen Concentration

The measuring principle of heat of reaction needs a minimum oxygen concentration of 15 % by volume; otherwise the measuring values will be too low because of oxygen deficiency.

3. Long-term Gassing With Methane at Very Low Temperatures

If the Prosense PC3 series flammable gas detectors are operated applying with methane at very low temperatures, the measuring signal at long-term exposition may decrease after alarm activation and may lead to misinterpretation. In this conditions if a gas alarm occurs, necessary actions need to be taken immediately. The decrease of the measuring signal should not mean that the gas concentration has been decreased. We recommend to keep alarms on the associated controllers and not to reset these alarms without making sure conditions are safe.

Introduction

The Prosense comprises a gas detector body and a choice of sensors heads for detecting flammable gas, toxic gas and oxygen. The construction of Prosense PC3 Series detectors allows it to be used in Zone2 or other areas not classified as hazardous.

Prosense detectors can be configured with a wide range of different sensors may be used to detect a broader range of target gases. The detector can be configured with optional relay board features three programmable relays for controlling external equipment e.g. alarms, sirens, valves or switches. The detector provides an industry standard 3-wire, 4-20mA output for connection to a dedicated gas detection control system or PLC.

Prosense detectors comprises of the main parts as shown below:

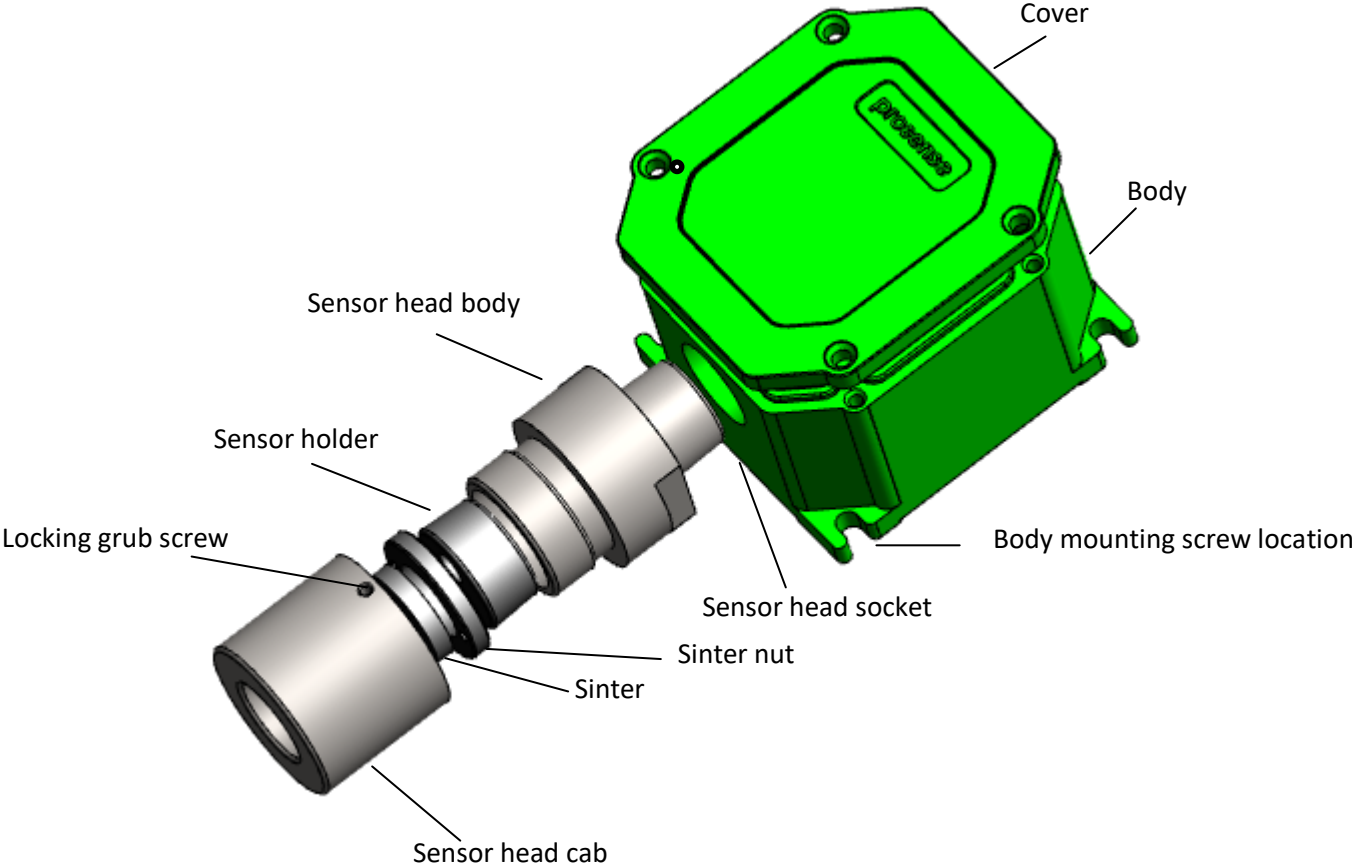

Diagram 1: Exploded view

Detector Body

The detector enclosure has two threaded entries. One is at upper part of the transmitter housing are for connecting the power source, signal output and relay contacts to associated signalling equipment. The bottom entry allows direct connection of the sensor socket. There are three special screw locations to mount detector to wall. The detector body dimensions are given in Diagram 2.

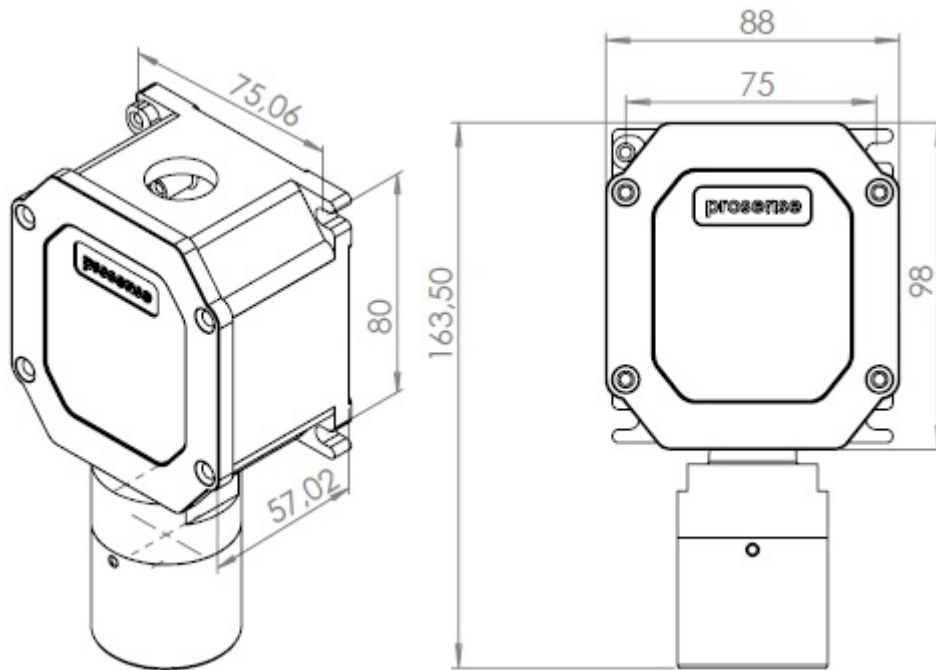

Diagram 2: Detector body dimensions

Sensor Head:

The Prosense sensor head designed to detect flammable, toxic and oxygen gases. Sensor head may include electro catalytic or electrochemical sensors. PC3 Series uses SH20 sensor head and components are given in Diagram 1.

Installation:

Gas detectors should be mounted where a potential hazard of gas is most likely to be present. The following points should be noted when locating gas sensors.

- When locating detectors consider the possible damage caused by natural events e.g. rain or flooding.
- Consider ease of access to the gas detector for functional testing and servicing.
- Consider how escaping gas may behave due to natural or forced air currents.

Note: The placement of gas detectors should be determined following the advice of experts having specialist knowledge of gas dispersion, experts having knowledge of the process plant system and equipment involved safety and engineering personnel. The agreement reached on the location of detectors should be recorded.

Each gas has different nature depending on their density. The density of which is lower than air, such as hydrogen, methane or ammonia the sensor head must be located above a possible leak or at the highest points at which major concentrations of gas may be found. The gases and vapours with a density greater than air, the sensor head must be installed beneath a possible leak or at the lowest points at which such gases and vapours may be present.

Prosense may provide cable gland together with detector in regards to customer requests. The cable gland provided by Prosense has ATEX/IECEX certification and provides at least IP65 level protection. The cable glands are only suitable for fixed installations. Cables shall be effectively clamped to prevent pulling or twisting. To provide necessary protection cable gland coupling should be fixed with 20Nm torque when used with three sealings; 18Nm when used with two sealing; 16Nm when used with one sealing. It is the final assemblers/users responsibility to ensure the threaded joint between cable gland and the enclosure meet all the requirements of the applicable standards for the assembly. Cable gland sealing are suitable for the circular type cables. If other shaped cables will be used the sealing should be replaced with suitable ones. The cable glands provided by Prosense are suitable to use temperature range in which detector works.

Mounting the Detector:

The detector should be mounted vertically as the sensor head pointing downwards. Detector has to be mounted such that the sensor's gas entrance area. The install location

- should be isolated from vibration, direct sun light and have temperature stability
- avoided external influences such as splashing water, oil, corrosive aerosols
- should have at least 30 cm free space beneath the sensor head to provide accessibility for calibration work.
- should be in air flow between possible leak or collection point and possible source of ignition.

Prosense do not recommend installing detectors to:

- directly above a cooking unit,
- directly above a sink unit,
- close to an extractor unit,
- outdoor without protection against the rain,
- in places where temperature is outside the admissible operating range,
- in corrosive environments,
- inside air vents.
- in environments where silicon can be found.

The Prosense PC3 detector has three mounting screw locations on body as given in Diagram 3.

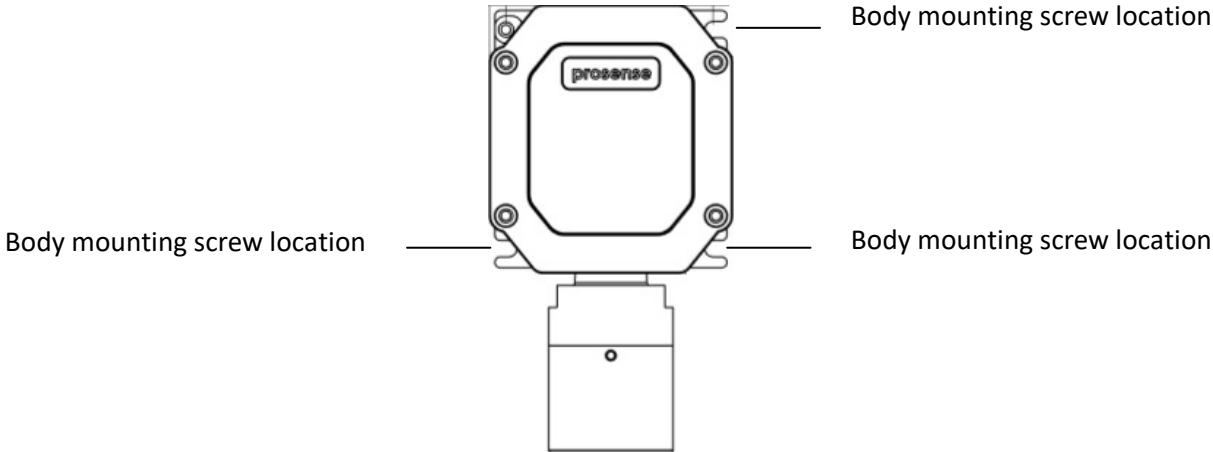

Diagram 3: PC3 detector mounting screw locations

Electrical Connections

Caution: All electrical connections should be made in accordance with any relevant local or national legislation, standards or codes of practice.

Prosense detectors can operate between 12 - 24 VDC. The connection socket located on main board as given in Diagram 7 and details given in below table 2:

Output	Usage
V +	Power input (+) 12VDC – 24VDC
V -	Power input (-)
S	Current Output Signal (4mA – 20mA)

Table 1: Detector output ports and their usage

The detector designed to give 4 - 20 mA current output signal. It is also possible to get voltage value via using an additional resistor between S and V- port and get voltage signal through this resistor. Below table gives recommended resistor specifications to get correct voltage output from detector depending of the desired voltage range:

Detector Power VDC	Resistor	Signal level (4mA – 20mA)
12 VDC – 24 VDC	250 Ω, tolerance %1	1 VDC – 5 VDC
12 VDC – 24 VDC	500 Ω, tolerance %1	2 VDC – 10 VDC

Table 2: Detector power and the output resistor

Please consider the cable length when performing installation in the field. The Prosense detector requires a power supply between 12VDC and 24VDC. Make sure that a minimum 12 VDC supply available at the detector entrance and consider the voltage drop due to cable resistance in case of long distance applications.

The maximum loop resistance in the field cable is calculated as follows:

$$R_{loop} = (V_{controller} - V_{detector\ min}) / I_{detector}$$

Example;

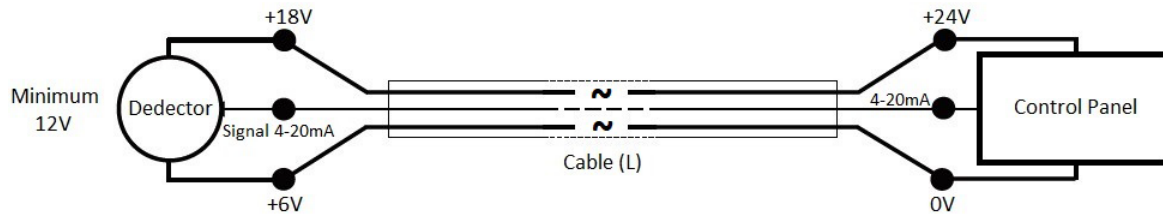

Diagram 4: Field cabling

The controller or power supply is supplying a nominal 24VDC (V controller), the detector minimum allowable voltage is 12VDC (V detector min), therefore the maximum allowable voltage drop between the controller and detector is 12VDC; this means a voltage drop of 6V in each core (V+ core and V- core). Minimum power consumption of the detector without any optional module is 1W. The current required to drive the detector at the minimum voltage is ($I = P / V$): $1.0 / 12 = 85\text{mA}$ (I detector).

Maximum power consumption of the detector when optional relay modules installed and all relays are active is 5.0W. The current required to drive the detector at the minimum voltage is ($I = P / V$): $5.0 / 12 = 416.6\text{mA}$ (I detector). So, the maximum field cable loop resistance (R_{loop}) = $12 / 0.41 = 29\ \Omega$, or 15 Ω per core, (allowing for component variations, losses, etc.).

The following tables show the maximum cable distances between the controller and transmitter assuming a voltage drop of 6V in each core and for different cable parameters. The tables are examples only and actual cable parameters and source power supply voltage for the application should be used to calculate the maximum cable distance allowed at the installation site. Typical cable data for detector with relay module

Cable size (cross sectional area)	Cable type nearest equivalent	Cable resistance Ω/km	Maximum Cable length (L) Meters
0.5mm ²	20AWG	36.8 Ω/km	407
1.0mm ²	17AWG	19.5 Ω/km	769
1.5mm ²	16AWG	12.7 Ω/km	1181
2.0mm ²	14AWG	10.1 Ω/km	1485
2.5mm ²	13AWG	8.0 Ω/km	1875

Table 3: Typical cable details and maximum distance for cabling

Cabling

The use of industrial grade, suitably shielded field cable is recommended. The best practices shown that, screened 3 cores (plus screen 90% coverage), suitably mechanically protected copper cable with a suitable explosion-proof gland, or 3/4" NPT steel conduit, depending on the distance between signal received or control panel and detector 0.5 to 2.5 mm² (20 to 13 AWG) conductors can give better results. Ensure the cable gland is installed correctly and fully tightened.

Cable and Earth/Ground regimes

Effective Earth/Ground bonding is important to ensure good EMC and RFI immunity. The following diagrams show examples of how to earth/ground bond the cable at enclosures. The same principles apply to conduit installations. These bonding techniques provide good RFI/EMC performance. Earth/ground loops must be avoided to prevent the risk of false signal variation.

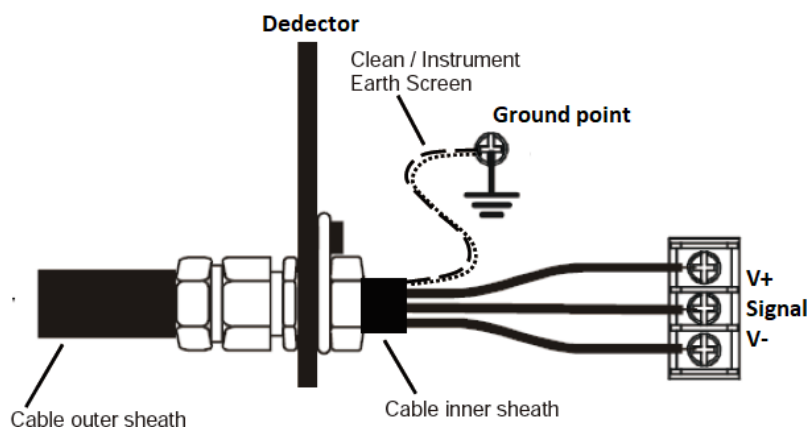

Diagram 5: Grounding

The Earth Screen of the field cable should be “tied to Earth” or connected to Ground at one point only. It is common practise to adopt a STAR EARTH connection regime where all instrumentation Screens are connected at one common point. The Screen at the other end of the cable should be “parked” or terminated into a blank terminal.

Detector Grounding

Internal Ground connection: Each detector has grounding screw which utilizes grounding for detector main PCB to detector body. The screw should be located correctly and fixed for all times. In case of any maintenance activity this screw should be checked and fixed to make sure for proper grounding.

External Ground Connection: It is recommended to utilize a No 14 AWG copper, (Stranded or Solid), wire. Loosen the screw sufficiently to enable 'wrapping the wire around the screw in a "U" shape. Raise the clamp and place the wire between the clamp and ground base, lower the clamp and tighten the screw to 10.4lb-in torque.

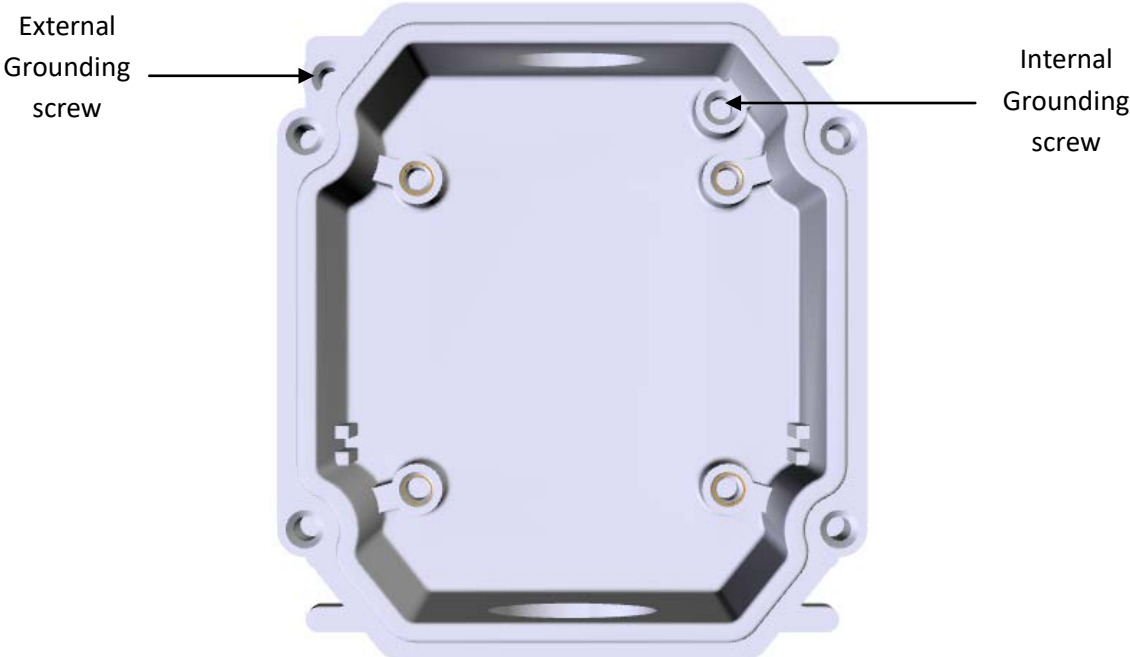

Diagram 6: Detector grounding screw

Default Configuration

Prosense detectors preconfigured to provide signal from analogue output depending on the detector and gas type. The output signal levels are given in below:

Function	Value/Setting	Meaning
Signal output	2.0 mA	Fault
	2.0 mA to 2.5 mA	Warm-up
	4.0 mA to 20.0 mA	Normal gas measurement
	21.0 mA	Maximum over range

Table 4: Detector default configuration details

Detector Main board and connection details given in Diagram 7:

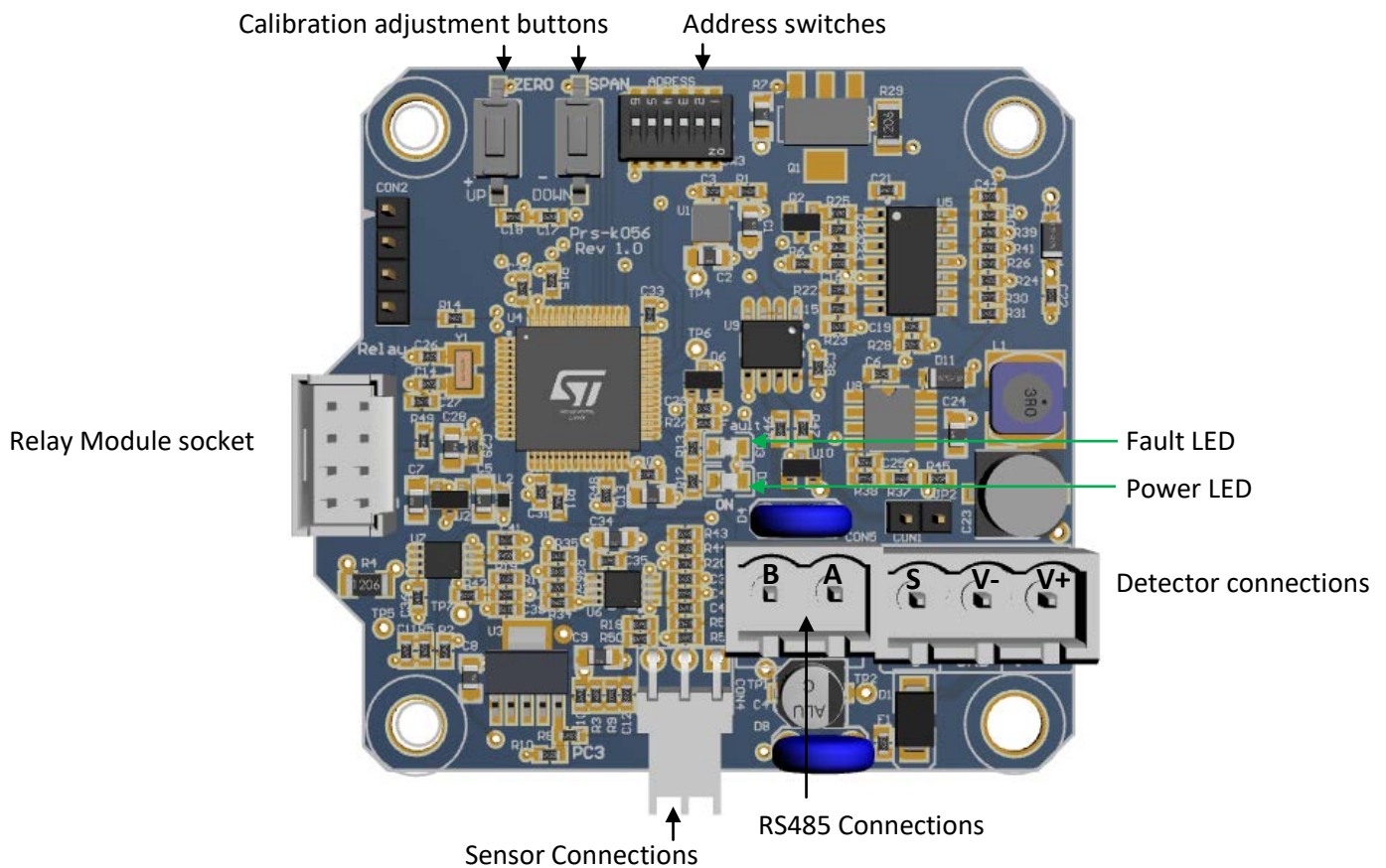

Diagram 7: Detector main board and connections

Sensor connections are input to detector main board and already connected to sensor inside the sensor head. Sensor connections must never be disconnected or changed. Only detector connections (V+, V- and S or RS485 A-B) must be used for external connections.

Detector Configuration

The Prosense detector has three different types of connection depending on usage:

1. 4-20mA output
2. RS485 Modbus serial communication output
3. 3-Relay outputs

It is possible to use 4-20 mA output with other output options at same time. The detector power connections are located on main board and this connection must be done in any case even 4-20mA analogue output is not used

4-20 mA Output:

The default configuration provides single 4-20mA signal output. Prosense detectors can be connected to control panels on the market having 4-20mA input signal. Signal wiring from detector and the control panel should be carried out by shielded cables. Wires cross section depends on the distance between the control panel and the detector. The details given in power cabling are valid as well for signal output. We recommend to use values given in table 4 (see page 13) as cabling best practices. Please avoid any interruption in case any junctions on wires. The shield is to be grounded from the control panel side only and never connect the shield to the detector. Please make sure clutching or crimping apparatus are not loosen or oxidized.

Port	Usage
V +	Power input (+) 12VDC – 24VDC
V -	Power input (-)
S	Current Output Signal (4mA – 20mA)

Table 5: Detector 4-20mA output ports and their usage

RS485 Serial MODBUS Output:

PC3 Series detector has onboard RS485 communication feature and RS485 MODBUS connections are located onboard on a separated socket. The detector connection should be made by 4 wire that 2 for power and 2 for RS485. The total length of the connection line should not exceed 800 meters. The wiring for detectors utilized with RS485 board should be done by using connection cable EIA RS485 2 core wires with section 0.22 / 0.35 mm² and shielded. Nominal capacity between the wires should < 50pF/m and nominal impedance is 120 Ohms.

Port	Usage
V +	Power input (+) 12VDC – 24VDC
V -	Power input (-)
A	MODBUS RS485-A
B	MODBUS RS485-B

Table 6: Detector RS485 output ports and their usage

Detectors will be wired in daisy chain (bus) mode. We recommend not using star mode connection due to negative impact of interference. Each detector should have unique address number in the chain. The detectors would not be recognised by control panel if same address given to them. The address of detector can be adjusted via using DIP-Switch set on the board:

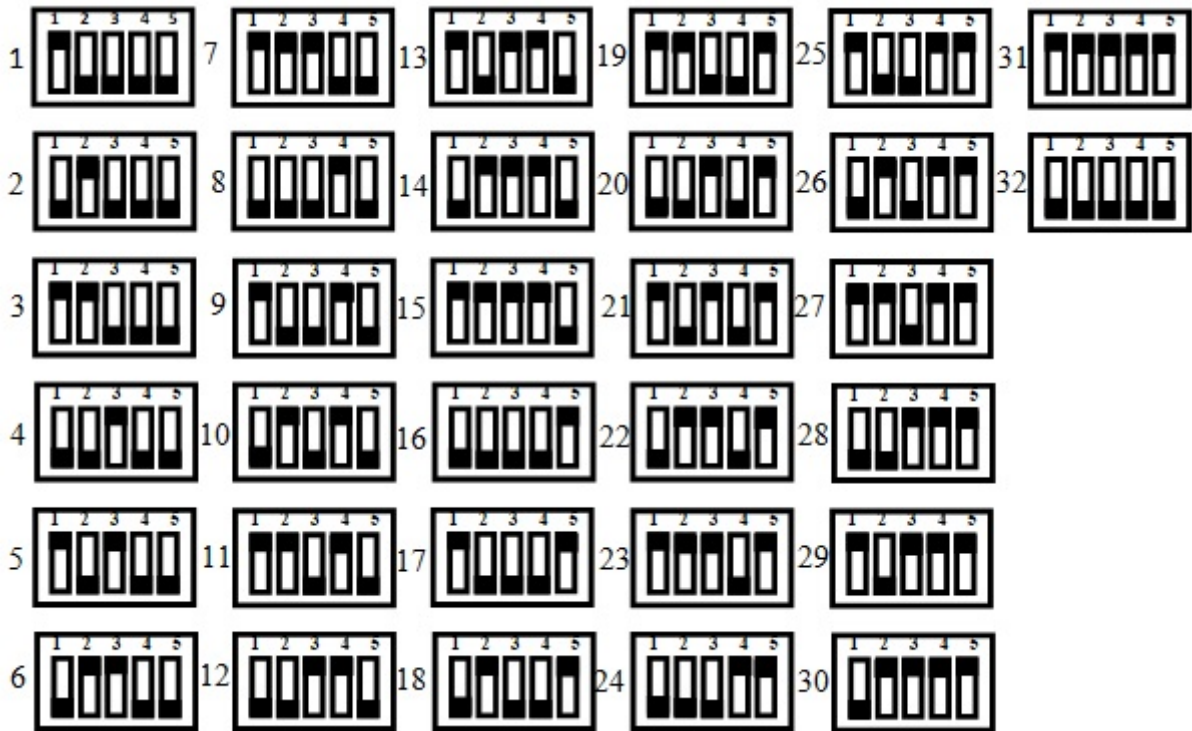

Diagram 8: RS485 Modbus serial communication address and switch position

The last detector in the chain should have 120 Ohm RS485 termination resistor. The resistor is already implemented on the board by default but not activated. User should activate the termination resistor via using the termination pin once the installation completed.

The power connection we recommend to use separate 2 wire cable with specification given earlier in this document (see Electrical Connections section at page11). Once the cabling is completed please check each detector has at least 12 VDC power.

Detector Relay Module:

The relay module details are given below:

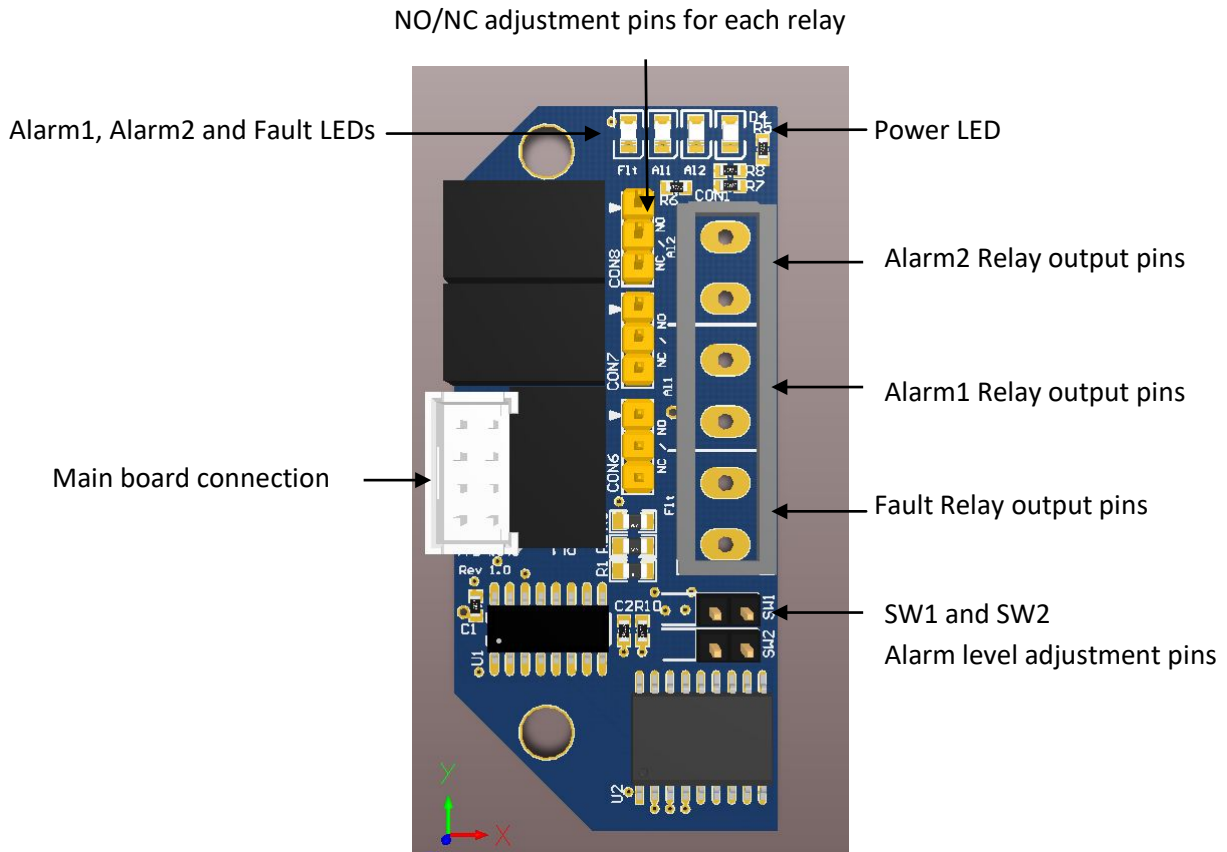

Diagram 9: Relay module

The relay board has 3 relay outputs:

Port	Usage	Energy	Contact
Fault	Fault Relay output	Energised	NO
AI1	Alarm 1 Relay output	Non-Energised	NO
AI2	Alarm 2 Relay output	Non-Energised	NO

Table 7 : Relay module output ports and their usage

All output pins located on Prosense IR detector can be used simultaneously. That means user can use all relay outputs, analogue (4-20mA) output and RS485 digital output at same time if implementation equipment allows their usage.

Each relay has 3 pins to adjust how to behave in case of alarm which are

NO : Normally Open

NC : Normally Close

The relay output pin positions shown below:

	Normally Open (NO)
	Normally Close (NC)

Table 8 : Relay output pin positions

The Fault relay is set to NO (Normally Open – Energised) and energised. Hence fault relay LED is always active. It does not mean that there is a fault on detector. If the power LED is active and fault LED is off it means that there is a fault condition on the detector. The fault relay will be de-energized in case of power failure.

The alarm relays set to NO (Normally Open – De-Energised) position at factory.

The alarm levels are also adjustable via using SW1 and SW2 alarm level pins. Alarm levels are defined as percentage in LEL for flammable gases. The alarm levels can be adjusted using jumpers to switch SW1 and SW2. Possible options are given in table 9:

SW1	SW2	Al1 Level	Al2 Level
Open	Open	10 LEL	15 LEL
Open	Closed	10 LEL	20 LEL
Closed	Closed	20 LEL	25 LEL
Closed	Open	20 LEL	40 LEL

Table 9: Alarm level pin positions

Oxygen Detectors:

For oxygen detectors the output values and meanings are different as oxygen is naturally available in atmosphere:

Port	Usage	Energy	Contact
Fault	Fault Relay output	Energised	NO
AL1	Alarm 1 Relay output - Lower level for Oxygen	Non-Energised	NO
AL2	Alarm 2 Relay output - Higher level for Oxygen	Non-Energised	NO

Table 10: Relay module output meanings for Oxygen detectors

Alarm levels are also different as given in below table:

SW1	SW2	Al1 Level	Al2 Level
Open	Open	19 %vol	23 %vol
Open	Closed	19 %vol	22 %vol
Closed	Closed	18 %vol	22 %vol
Closed	Open	18 %vol	23 %vol

Table 11: Alarm level (% Vol) pin positions for Oxygen detectors

System Status

The Prosense PC3 detector has two LEDs on main board. Red LED shows system power status and yellow LED shows fault status. Both LEDs will be illuminated right after applying power. After approximately 90 sec the yellow LED will be turned off and only red LED will continue blinking. This status means that detector is ready to normal operation. Detector will provide

2mA analogue signal output during warm-up period and current level will be 4mA after warm-up.

Here is the LED status table during warm-up, normal operation and fault status:

LED	Warm-up	Normal Operation	Fault Status
Power -Red	Blinking	Blinking	Blinking
Fault - Yellow	Blinking	Solid - Off	Solid - On

Table 12: LED status details

First Time Switch on (Commissioning)

WARNING: The following procedure requires the detector Cover to be removed while carrying out supply voltage checks. Therefore the appropriate permits to work should be sought in preparation. Prior to carrying out any **HOT WORK** ensure local and site procedures are followed. Ensure that the associated control panel output actuation is inhibited so as to prevent false alarms. The following procedure should be followed carefully and only performed by suitably trained personnel

1. Remove the detector cover
2. Configure the analogue output signal and power input connections correctly
3. Check that all electrical connections are terminated correctly
4. Switch On the external power supply to feed the detector
5. Using a Digital Multi Meter (DMM), check the Supply Voltage at the terminals V+ (24V) and V- (0V), this should be a minimum supply voltage of 12VDC (Maximum supply voltage is 24VDC)
6. Check LED status on detector main board. Both LEDs will be illuminated right after applying power.
7. Wait two minutes and confirm that the yellow LED turned off and only red LED blinking.
8. Switch Off the external power to the detector.
9. Fit the cover and make sure none of the cables cause an obstruction while fitting cover
10. Switch on external power to the detector.

Calibration

It is recommended to periodically carry out calibration to ensure correct operation. Detector should be powered and stabilized for at least 4 hours before calibration. For Flammable gas calibration use a calibration gas concentration of between 25%LEL and 75%LEL to ensure that the required accuracy can be attained. To calibrate the detector, use an appropriate span gas cylinder, constant flow regulator and Prosense Gas Cap. The calibration gas flow rate should be 0.5 L/min. It is recommended to use a compressed air cylinder (20.9%Vol oxygen) to perform the zero calibration if the area where the detector is located contains any residual amount of the target gas. If no residual gas is present then the background air can be used to perform the zero calibration. Calibration procedure should be completed for both zero and span adjustment steps. Calibration switches and adjustment buttons will be used on main board during calibration.

Zero Calibration button Span Calibration button

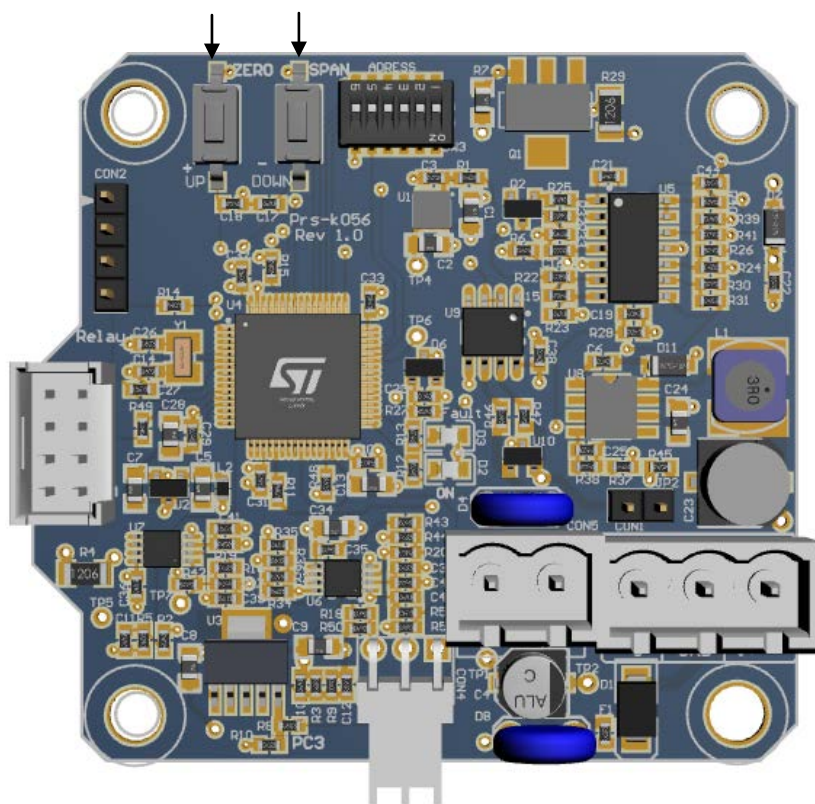

Diagram 10: Calibration buttons

Zero Calibration

The detector signal output should be 4 mA when there is no target gas exist on the area or a clean compressed air applied to detector. Use a multimeter to check signal output. If the signal output is different than 4 mA, enable the zero calibration via pressing to the zero calibration button for 10 seconds. Zero calibration switch is shown on Diagram 8. After holding it pressed for 10 seconds, the red power LED will be solid lit meaning zero calibration process is started. The detector automatically adjusts the output signal level to 4 mA for the next 30 seconds, assuming the detector is in a fresh air environment. If the ambient air is not clean, clean air cylinder should be used to give clean air to the sensor head at a constant speed of 0.5 lt/min using the calibration head. After 30 seconds, the detector completes the zero calibration process and the power LED flashes once per second at normal speed.

Span Calibration

Span calibration must be done by exposing the detector a known gas. In first step zero calibration should be completed. The current level should be monitored continuously at the detector output using a measuring instrument DMM. Then, the calibration head should be attached to the sensor head and gas should be applied to the sensor using a regulator at a constant flow rate of 0.5lt / min. The span calibration button shown in Diagram-8 must be pressed for 10 seconds to start the span calibration. After holding it pressed for 10 seconds, the red power LED will be solid lit meaning the span calibration process is started. Depending

on the concentration level of the gas used for calibration, the current value measured at the detector output will be different. Span calibration lasts 30 seconds. If the value measured from the detector is higher than the reference value while applying gas, the zero calibration button should be pressed until the current level is reduced to the reference value. If the measured value is lower than the reference value, the span calibration button must be pressed until the current level is increased to the reference value. The button functions changes automatically when the span calibration process has started: zero calibration button decreases the current level and span calibration button increases the current level. After 30 seconds, the calibration will be completed automatically and the adjusted level will be saved. When the span calibration is completed, gas flow should stop and calibration cap should be removed from sensor head

Important: Do not press both buttons.

Maintenance

Important: All replacement actions (sensor, sinter, and sensor head) shall be done by Prosense service personnel as it needs some special steps that should be performed in laboratory environment.

Proactive Maintenance:

All gas detectors including both for flammable and toxic gases should have to pass a functional test and calibration periodically according to industrial standards. The test results and calibration reports should be recorded in maintenance books.

To make sure the detectors functioning correctly company should prepare detector check procedures. The procedures should include daily, weekly and monthly check activities depending of the environmental and process conditions. The control panels will report fault condition in case detector analogue output provides signal 0-2,5mA levels. Also they will report fault in case they could not communicate to the detector.

It might be necessary to perform bump test to make sure detectors responding correctly to test gases. If any detector does not respond to the test gases, it should be removed from the operations and send to service for repair. Detector sensor head should be clean and open to gas diffusion without any obstacle. Sensor head should not be washed with pressurised water or gases.

Operational Life:

Catalytic/Pellistor flammable gas sensor made by using the pellistor that suffer from a loss of sensitivity when in the presence of poisons or inhibitors, e.g. silicones, sulphides, chlorine, lead or halogenated hydrocarbons. The pellistor are poison resistant to maximize the operational life of the Catalytic flammable sensor. A typical operating life, subject to the presence of poisons/inhibitors and environment conditions is 48-60 months. The NDIR (infrared) flammable gas sensor is not affected by the mentioned poisons hence has a longer

life span. Pellistor sensors can suffer degradation and shorten the life if powered while exposed to flammable gas concentrations greater than 100% LEL, and also if exposed to high levels of H₂S or silicones.

Typical life of a toxic gas sensor which made by electrochemical component is dependent on the application, frequency and amount of gas exposure. Under normal conditions (visual inspections every 3 month and test/recalibration every 6 month), the Prosense oxygen and toxic gas detector sensors have an expected life equal to or greater than 24 months.

Persistent exposure to high levels of toxic gas can shorten the life of toxic sensors. Toxic sensors may also be cross-sensitive to gases other than their specific target gas, and hence the presence of other gases may cause the sensor to respond.

Sensor Replacement:

The Flammable Catalytic and Toxic ECC cells that are used with the Prosense Sensor Head have no serviceable parts. When they have reached the end of their operational life, simply replace the cell. All replacement actions (sensor, sinter, and sensor head) have to be done by Prosense service personnel as it needs some special steps should be performed in laboratory environment.

Sinter Replacement:

Due to environmental conditions the metal filter - sinter at sensor head might lost permeability that could negative impact on sensor performance. For example if the installation includes cement or similar dust the sinter would be block the air/gas entry to sensor. The sinter should be checked visually and replaced if necessary. To replace sinter please check Diagram-1 and follow the below procedure:

- 1- Power of the Prosense detector
- 2- Loosen the locking grub screw
- 3- Unscrew the sensor head cap that holds the dirty sinter
- 4- Screw the sensor head cap including the clean sinter
- 5- Fix the Locking grub screw

Sensor Head Replacement:

Prosense sensor head is a separate part that can be replaced in the field. The sensor head includes integrated sensor, electronic device and sinter in it. To replace sensor head:

- 1- Power-Off the Prosense detector
- 2- Disconnect sensor cables from the detector main board
- 3- Remove the sensor head from the body
- 4- Install sensor head
- 5- Connect the sensor cables to detector main board
- 6- Power-On Prosense detector
- 7- Leave detector working at least 4 hours in clean air environment
- 8- Perform full calibration for detector including zero and span calibration steps

General Specification

Use:

Gas detector with default 3-wire, 4-20mA output for the protection of personnel and plant from flammable and toxic gas hazards.

Electrical Specifications:

Input Voltage Range	12 to 24VDC (24VDC nominal)
Max Power Consumption	Max 5 Watts. at 24VDC
Current output	4-20mA
2.0 mA	Fault
4.0 mA to 20.0 mA	Normal gas measurement
2.0 mA to 2.5 mA	Inhibit (during configuration/warm-up)
21.0 mA	Maximum over range
Terminals	3 x screw terminals suitable for wire diameter 0.5mm ² to 2.5mm ² (20AWG to 13AWG).
	2 x screw terminals (0.5mm ² - 2.5mm ² (20AWG to 13AWG) for RS485
	6 x screw terminals (0.5mm ² - 2.5mm ² (20AWG to 13AWG) for Relays
Relays	3 x (1A 30VDC, 0.5A 125VAC, 0.3A 80VDC). Selectable normally open or normally closed (switch) and de-energized.
Communication	RS485, Modbus RTU

Table 13: Electrical specifications

Detector Body Specifications:

Material	Epoxy painted aluminium alloy (Sensor head is nickel plated brass)
Weight	Aluminium Alloy :1.33kg (with Sensor Header)
Mounting	Wall mounting
Entries	½ NPT field cable entry, ¾ NPT sensor entry

Table 14: Detector body specifications

Environmental:

IP Rating	IP65
Operating Temperature	-20°C to +50°C / -4°F to +120°F
Operating Humidity	Continuous 20-90%RH (non condensing) Intermittent 10-99%RH (non condensing)
Operating Pressure	90-110kPa
Storage Conditions	-30°C to +70°C (-22°F to +158°F)

Table 15: Environmental specifications

Certification



Manufacturer Declaration of Conformity



Prosense Teknoloji San Ltd. Şti declares the PC3 Series products to be in accordance with the following standards and directives.

Name and address of Manufacturer: **Prosense Teknoloji San Ltd Şti**
Cumhuriyet Mah. Mermer Sok No:16
34876 - Kartal – İstanbul – Türkiye

Description of Devices: PC3 Series Fixed Type Gas Detectors

Applied Harmonized international standards (for Sensor Head):

EN/IEC 60079-0:2018 Equipment – General requirements
EN/IEC 60079-1:2014 Explosive atmospheres - Part 1: Equipment protection by flameproof enclosures 'd'
EN/IEC 60079-18:2015 Explosive atmospheres - Part 18: Equipment protection by encapsulation "m"
EN/IEC 50270:2015 Electromagnetic compatibility - Electrical apparatus for the detection and measurement of combustible gases, toxic gases and oxygen

Applied European Directives:

2014/34/EU ATEX Directive
2014/30/EU Electromagnetic Compatibility (EMC) Directive

Each PC3 Series gas detector device which the Production Quality Assurance procedures and Type Examination procedures have been applied has been shown to conform to an approved Type and to the applicable classification rules and essential principles before being supplied. This declaration is being made on the basis of the following certificates:

Quality Management Certificate: **18ISO0073**
Production Quality Assurance Certificate: **ExVeritas 18PQAN0072**
Type Examination Certificate (for sensor head): **IEP 12 ATEX 118 X**

Authorised Signatory:

Firat Celep
Production Manager

Date: 26.12.2020

Warranty Statement

All products are designed and manufactured to the latest internationally recognized standards by Prosense Technology under a Quality Management system that is certified to ISO 9001. As such Prosense Technology warrants its products against defective parts and workmanship and will repair or (at its option) replace any instruments which are or may become defective under proper use within 12 months from date of commissioning by an approved Prosense Technology representative or 18 months from date of shipment from Prosense Technology, whichever is the sooner. This warranty does not cover disposable batteries or damage caused by accident, abuse, abnormal operating conditions or poisoning of sensor.

Defective goods must be returned to Prosense Technology premises accompanied by a detailed description of any issue. Where return of goods is not practicable Prosense Technology reserves the right to charge for any site attendance where any fault is not found on the equipment. Prosense Technology shall not be liable for any loss or damage whatsoever or howsoever occasioned which may be a direct or indirect result of the use or operation of the Contract Goods by the Buyer or any Party.

This warranty covers instrument and parts sold to the Buyer only by authorized distributors, dealers and representatives as appointed by Prosense Technology. The warranties set out in this clause are not pro rata, i.e. the initial warranty period is not extended by virtue of any works carried out there under.

In no event will Prosense Technology be liable for any incidental damages, consequential damages, special damages, punitive damages, statutory damages, indirect damages, loss of profits, loss of revenues, or loss of use, even if informed of the possibility of such damages. Prosense Technology's liability for any claims arising out of or related to this product will in no case exceed the order value. To the extent permitted by applicable law, these limitations and exclusions will apply regardless of whether liability arises from breach of contract, warranty, tort (including but not limited to negligence), by operation of law, or otherwise.