



PROSENSE PQ Series Gas Detectors User and Safety Manual



Prosense Teknoloji San. Ltd. Şti.
Cumhuriyet Mah. Mermer sok. No:16 Kartal İstanbul
Tel: (90) 216 306 77 88 Faks: (90)216 473 81 29
www.prosense.com.tr

WARNING!
READ THIS INSTRUCTION FIRST!

This manual must be carefully read by all persons who have or will have the responsibility for installing, using or servicing this product.

Like any equipment, this product will perform as designed only if installed, used and serviced in accordance with the manufacturer's instructions. Otherwise, it could fail to perform as designed and persons who rely on this product for their safety could suffer severe personal injury or death.

The warranties made by Prosense with respect to this product are voided if the product is not installed, used and serviced in accordance with the instructions in this user guide. Please protect yourself and other by following them.

CAUTION

This product has been tested and approved for use in hazardous areas. However, it must be properly installed and used only under the conditions specified within this manual and the specific approval certificates. Any device modification, improper installation, or use in a faulty or incomplete configuration will render warranty and product certifications invalid.

Important Remark

The detector has been factory-tested before delivery. The commissioning has to be terminated by a function test of the complete gas detection system.

DO NOT REMOVE COVER WHEN ENERGISED!



ELECTROSTATIC HAZARD - CLEAN ONLY WITH A DAMP CLOTH!

For DIVISION APPLICATIONS, DO NOT OPEN COVER WHEN EXPLOSIVE GAS ATMOSPHERE MAY BE PRESENT.

Please contact info@prosense.com.tr for any inquiry or complaints.

Contents

Safety Information.....	6
Strictly follow the Instructions for Use.....	7
Maintenance.....	8
Use in areas subject to explosion hazards	8
Liability for proper function or damage	8
Intended Use	8
Hazardous area classifications:	8
Special Condition of Use:.....	10
Introduction.....	11
Prosense PQ Series Configuration Options	12
Model Options:.....	12
Cable Entry Type Options:	12
Build and Certification Options:	12
Explosion-Proof Specification.....	13
Detector parts	14
Detector body.....	15
Sensor Head.....	16
Installation.....	16
Mounting the detector	18
Electrical connections.....	19
Cabling.....	21
Detector grounding	22
PQ Series Detector Configuration	23
4-20 mA output:	23
RS485 serial communication output:	24
Relay module:.....	25
Oxygen detectors:	26
HART Module	27
System Status	28
Indication of measured values	29
Warmup.....	29
Fault.....	29
Alarm	29
Calibration	30
Underrange.....	30
Overrange.....	30
Commissioning	31
Commissioning PQD/PQD-S	31
Commissioning PQN / PQN-S	32
Detector Settings.....	33
Entering the menu:.....	33
Menu structure.....	34
Alarm Settings	34
Configure	36
Change date and time	36
Change Modbus address	37
Change Analogue Output	37
Display Parameters.....	37

Change Language.....	38
Change Zero Suppression	38
Change password	38
Bump Test.....	39
Change Test Interval.....	39
Adjust Inhibit warning	39
Information Menu options	41
Display Event Logs	41
Display Concentration Trends	41
Display Measurements.....	42
Display Transmitter information	42
Display Transmitter information	42
Test Menu Options	43
Run Inhibit test	43
Run Display test.....	44
Run Relay test.....	44
Run Analogue Output test.....	45
Run Bump Test	45
Calibration	47
Set Reference Gas details.....	48
Set Calibration Cycle.....	49
Zero Calibration	49
Span Calibration	50
Cancel Calibration.....	50
Maintenance	51
Proactive maintenance:.....	51
Operational Life:.....	51
Battery	52
Sensor replacement:	52
Pellistor sensor replacement:.....	52
Electrochemical sensor:.....	52
Infrared Sensor:	53
Sensor PCB replacement:	53
Sinter replacement:.....	53
Sensor head replacement:	53
Detector Transmitter board replacement:.....	54
PQD Detector Display Module replacement:	55
Detector Relay Module replacement:.....	55
Safety Manual for PQD-S / PQN-S models with Pellistor sensor board (PRS-K033)	56
Safety Concept	56
Safety Function:.....	57
Safety State	57
Analogue Output Safety State:.....	57
Switching Output Safety State.....	59
SIL Capability	60
Proof Test Interval	62
Proof test procedure	62

A. Inspect PQD-S / PQN-S	62
B. Re-Calibrate PQD-S / PQN-S	62
C. Execute PQD-S / PQN-S Tests	62
Special Notes	63
Fault Status Codes:	64
Spare Parts.....	65
General specification.....	67
Electrical Specifications:	67
Detector Body Specifications:	67
Environmental:	67
Default Configuration:.....	68
Performance and Configuration Data:	69
SAFETY INSTRUCTIONS FOR HAZARDOUS AREA INSTALLATION	74
Declaration	76
Warranty statement.....	78
Exclusions	78
Warranty Limitation and Exclusion	78
Limitation of Liability	79

Safety Information

FOR SAFETY REASONS THIS EQUIPMENT MUST BE OPERATED AND SERVICED BY QUALIFIED PERSONNEL ONLY. READ AND UNDERSTAND INSTRUCTION MANUAL COMPLETELY BEFORE OPERATING OR SERVICING.

CAUTION

A HIGH OFF-SCALE READING MAY INDICATE EXPLOSIVE CONCENTRATION.

Observe these precautions:

- To minimize the risk of electrostatic charge, provision shall be made for adequate grounding and equipment shall be installed in such a manner so that accidental discharge shall not occur.
- When Prosense PQ reaches the end of its life, it should be disposed of in accordance with local regulations.
- Do not use cleaning solvents or abrasives to clean the gas detector.
- Do not attempt to modify the product in any way from the manufacturers design or specification. Warranty will be void and malfunction of the gas detector may result.
- Use only genuine spare parts and accessories with Prosense PQ. Malfunction may result if non-standard parts are used.

WARNING

- Prosense PQ is designed for installation and use in Zone 1/ or Zone21/22 hazardous areas in many countries including Europe and for Class 1 Division 1 or 2 area applications in North America.
- Installation must be in accordance with the recognized standards of the appropriate authority in the country concerned.
- Access to the interior of the detector, when carrying out any work, must only be conducted by trained personnel.
- Before carrying out any work ensure local regulations and site procedures are followed. Appropriate standards must be followed to maintain the overall certification of the detector.
- For installations where conduit is used, there must be a “Seal Fitting” installed for each of the cable gland entries within 18 inches of the Prosense PQ. The total distance of the location of these Seal Fittings is 18 inches. (e.g. If both gland entries are to be used, 2 Seal Fittings should be located, each within 6 inches of the wiring entrance).
- In order to maintain electrical safety, the product must not be operated in atmospheres with more than 21% oxygen. Oxygen deficient atmospheres (Combustible: less than 10%V/V, Toxic: less than 6%V/V) may suppress the sensor output.
- If using an anti-seize compound, the threads should be thinly coated with an approved silicone-free compound e.g. petroleum jelly
- To reduce the risk of ignition of a hazardous atmosphere, de-classify the area or disconnect the equipment from the supply circuit before opening the detector enclosure. Keep assembly tightly closed during operation.
- Never attempt to open the enclosure or replace/refit the sensor in potentially hazardous atmospheres or while power is still applied to the transmitter.
- The detector must be earthed/grounded for electrical safety and to limit the effects of radio frequency interference. Earth/ground points are provided inside and outside the unit. The

internal grounding shall be used as the primary equipment ground. The external terminal is only a supplemental bonding connection where local authorities permit or require such a connection.

- Ensure that all screens/instrument earth/clean earth wiring is earthed/grounded at a single point (either at the controller or detector, BUT NOT BOTH) to prevent false readings or alarms that may occur due to potential earth/ground loops.
- Take care when handling sensors as they may contain corrosive solutions. Do not tamper with or in any way disassemble the sensor.
- Do not expose to temperatures outside the recommended ranges.
- Do not expose sensors under storage conditions to organic solvents or flammable liquids.
- At the end of their working life, replaceable electrochemical sensors for oxygen and toxic gas must be disposed of in an environmentally safe manner. Disposal should be according to local waste management requirements and environmental legislation.
- Alternatively, old replaceable sensors may be securely packaged and returned to Prosense clearly marked for environmental disposal.
- Electrochemical sensors should NOT be incinerated as this action may cause the cell to emit toxic fumes.
- Refer to the local or national regulations relative to the installation at the site. For Europe see EN60079-29-2, EN60079-14, EN45544-4 and EN61241-14. For installations in North America, the National Electrical Code (NFPA 70) should be strictly observed. All the appropriate local and national regulations should be observed.
- This equipment is designed and constructed as to prevent ignition sources arising, even under fault conditions.
- Only the combustible gas detection portion of this instrument has been assessed for performance in IEC EN 60079-29-1.
- The pellistors used in the catalytic flammable gas sensor can suffer from a loss of sensitivity when in the presence of poisons or inhibitors, e.g. silicones, sulphides, chlorine, lead, or halogenated hydrocarbons.
- All accessories are NOT part of explosion-proof certificate.
- Do not repair flameproof joints.
- To reduce the risk of ignition of hazardous atmospheres, conduit runs must have a sealing fitting connected within 50 mm of the enclosure.

Strictly follow the Instructions for Use

Any use of the detectors requires full understanding and strict observation of these instructions. The detector is only to be used for purposes specified here.

The cover on Detector must be kept tightly closed until power to the detector is isolated otherwise ignition of a flammable atmosphere can occur. Before removing the cover for maintenance or calibration purposes, ensure the surrounding atmosphere is free of flammable gases or vapours.

Detectors must be protected from extreme vibration and direct sunlight in hot environments as this may cause the temperature of the detector to rise above its specified limits and cause premature failure.

Maintenance

It is recommended to obtain a service contract Prosense to carry out all repairs. Only authentic Prosense spare parts must be used, substitute components may invalidate the certification and warranty of the detector. Maintenance and calibration operations must only be performed by qualified service personnel.

Use in areas subject to explosion hazards

Equipment or components which are used in potentially explosive atmospheres and have been tested and approved according to international or European regulations may be used only under the conditions specified here. Modifications of components or the use of faulty or incomplete parts are not permitted. In case of repairs of equipment or components, the national regulations must be observed.

Liability for proper function or damage

The liability for the proper function of the detector is irrevocably transferred to the owner or operator to the extent that the detector is serviced or repaired by personnel not employed or authorized by Prosense or if the sensing head is used in a manner not conforming to its intended use. Prosense cannot be held responsible for damage caused by non-compliance with the recommendations given above. The warranty and liability provisions of the terms of sale and delivery of Prosense are likewise not modified by the recommendations given above.

Intended Use

The PQ series detectors are intended to be used for stationary, continuous monitoring for combustible gas/air or vapour/air mixtures below the Lower Explosion Limit (LEL) and toxic gas/air mixtures in particule per million (PPM) units. The measurement range and environmental conditions are written on each detector label.

According to the ATEX Directive 2014/34/EU, IECEx, UKEX standards the detector is an assembly consisting of three components (Sensor Head, enclosure and cable gland), where all these three components are type approved and marked by the device category II 2G. Thus this detector is suitable to be operated in hazardous areas with potentially explosive atmospheres of Zone 1/2 and Zone 21/22. The type of protection for gas explosion protection according to device category 2 is flameproof enclosure and increased safety, "db" and "tb" for dust applications. The enclosure protection is IP 65. For the determination of the measuring range and operating conditions, the label on the detector should be consulted.

Hazardous area classifications:

Zone 0: An area classified as Zone 0 will have ignitable concentrations of flammable gases, vapours or liquids either continuously present or present for long periods of time under normal operating conditions

Zone 1: An area classified as Zone 1 is likely to have ignitable concentrations of flammable gases, vapours or liquids present under normal operating conditions. Flameproof (Ex db) detectors are suitable for use in Zone 1.

Zone 2: An area classified as Zone 2 is not likely to have ignitable concentrations of flammable gases, vapours or liquids present under normal operating conditions. Flameproof (Ex db/tb) detectors are suitable for use in Zone 2.

Not to be used in oxygen enriched atmospheres.

In conjunction with the central controllers Prosense detectors with preadjusted alarm thresholds audible and visible alarm devices or automatic countermeasures can be activated before the detected gases or vapours can form dangerous flammable or toxic mixtures with air.

PQ series with pellistor sensor for flammable gas detectors are designed to detect gases or vapours in air and not inert or oxygen deficient atmospheres. Please be alerted in following special conditions may have impact on measuring function due to the nature of measuring method:

1. Very high gas concentrations

The measuring method of PQ series detector based on heat produced by reaction on the oxidation of a flammable gas when pellistor sensor used. There is not enough oxygen in the sensor to perform oxidation process correctly in case of high gas concentrations. Hence the measuring signal decreases at high gas concentrations and even can lead to measuring signal within the measuring range again. In case of high flammable gas concentration, do not reset latching alarms without having ensured a safe condition in the environment via performing necessary checks.

2. Minimum oxygen concentration

The measuring principle of heat of reaction needs a minimum oxygen concentration of 12 % by volume for PQ series detector with pellistor sensor; otherwise the measuring values will be too low because of oxygen deficiency.

3. Long-term gassing with methane at very low temperatures

If the Prosense PQ series flammable gas detectors with pelistör sensor are operated applying with methane at very low temperatures, the measuring signal at long term exposition may decrease after alarm activation and may lead to misinterpretation.

If a gas alarm occurs, necessary actions need to be taken immediately. The decrease of the measuring signal should not mean that the gas concentration has been decreased. We recommend to keep alarms on the associated controllers and not to reset these alarms without performing measurement with an independent gas detector to make sure conditions are safe.

4. Avoid exposure to Silicon complex

Prosense pellistor sensors high level of resistance to catalytic poisons like Hydrogen Sulphide (H₂S) and Silicones such as HMDS (HexaMethylDoSiloxane). But it is not suitable to use in environments which continuous exposure of poisoning elements.

Special Condition of Use:

1. Flamepaths must not be repaired
2. When the painted enclosure is intended for use in Group III applications, the end user must adhere to the manufacturer's instructions to minimise risk of electrostatic discharge
3. PQ Series gas detectors must be installed only with sensor head pointing downwards.
4. Cable glands and thread adapters used for entry into the enclosure, as well as blanking elements, shall be certified as Ex Components according to protection "d", and suitable for the ambient temperature range specified in introduction section.
5. Do not remove or replace the battery
6. All accessories are NOT part of the explosion-proof certificate.

Specific Condition of Use for CAN/CSA-C22.2 No.60079-0, 60079-1 and 60079-31

Condition d'utilisation spécifique pour CAN / CSA-C22.2 No.60079-0, 60079-1 et 60079-31

- To reduce the risk of ignition of hazardous atmospheres, conduit runs must have a sealing fitting connected within 50 mm of the enclosure.

Pour réduire le risque d'inflammation des atmosphères dangereuses, les conduits doivent avoir un joint d'étanchéité raccordé à moins de 50 mm de l'enceinte.

- Open circuit before removing cover.

Ouvrir le circuit avant de retirer le couvercle.

- Keep cover tight while circuits are alive.

GARDEZ LE COUVERCLE TOUJOURS SI LES CIRCUITS SONT VIVANTS.

- Temperature of the entry point or at branching point is above +70 °C under rated conditions.

La température du point d'entrée ou au point de ramification est supérieure à +70 °C dans des conditions nominales.

Introduction

The Prosense comprises a gas detector body and a choice of sensors heads for detecting flammable gases, toxic gases and oxygen. The construction of Prosense PQ Series detectors allows it to be used in hazardous area locations; it may also be used in other areas not classified as hazardous. The detector can be configured with optional relay board features three programmable relays for controlling external equipment e.g. alarms, sirens, valves or switches. The detector provides an industry standard 3-wire, 4-20mA output for connection to a dedicated gas detection control system or PLC. It can also provide RS485 serial communication with integrated onboard devices.

Prosense PQ series gas detectors are projected and built according to ATEX Directive 2014/34/EU, IECEx, UKEX and UL standards with reference to standard IEC EN 60079-0, IEC EN 60079-1 and IEC EN60079-31. All PQ series Detectors certified according to ATEX and IECEx standards. PQD-S and PQN-S models are also certified according to IEC EN 50402 to comply functional safety requirements. All models are builded in same way uses same user menu screens and parameters. User should check the product label to identify equipment model as all products looks similar.

PQ Series gas detectors for monitoring a very wide range of toxic and flammable gases and oxygen. PQ series are available as Flameproof (Ex db/tb) detectors suitable for use in Zone 1/2 and Zone 21/22 hazardous areas. Please refer to the certification label on the detector junction box to identify the type of certification that relates to the product supplied.

Prosense PQ series gas detectors may be installed in hazardous area with flammable gases, vapours, and mist, group II, category 2GD, maximum superficial permissible temperature 70°C.

Device category 2GD, Identification II 2GD

Ex db IIC T6 Gb (Tamb = -40 °C ÷ +70 °C) – For explosion protection

(Tamb = -20 °C ÷ +60 °C) – For performance requirements

Ex tb IIIC T85°C Db

It means:  (European Community logo for ATEX applications) – group II (potentially explosive atmospheres – surface application – OTHER than mines)

Category 2GD (G => Gas D=>Dust) – Zone 1 and Zone 2 /Zone 21 and Zone 22

Ex db => protection mode: explosion proof enclosure

IIC => define kind of gases

T6 => Temperature class -- Maximum allowable surface temperature.

IP 65 => Mechanical protection degree – protection against solid, dust and liquid.

Note: if no certification label is fitted to the junction box, the detector is not certified for use in hazardous areas.

Prosense PQ Series Configuration Options

PQ Series detectors are available as PQN and PQD names. PQD and PQN are uses same electronics, sensors, sensor heads and firmware. PQD has an integrated screen on detector itself and the cover has window made from glass while PQN has aluminium cover without window as it does not have screen. Prosense PQ Series detectors can be ordered with functional safety features with extended error recovery mechanism implemented SIL2 level functional safety certified electronics. These modes are named as PQD-S / PQN-S.

PQ Series Product marked based on below coding schema:

PQ (N/D)-(S)-(XY)(W)(Z)(T1/T2/T3) (NULL/C1/C2/C3/C4)

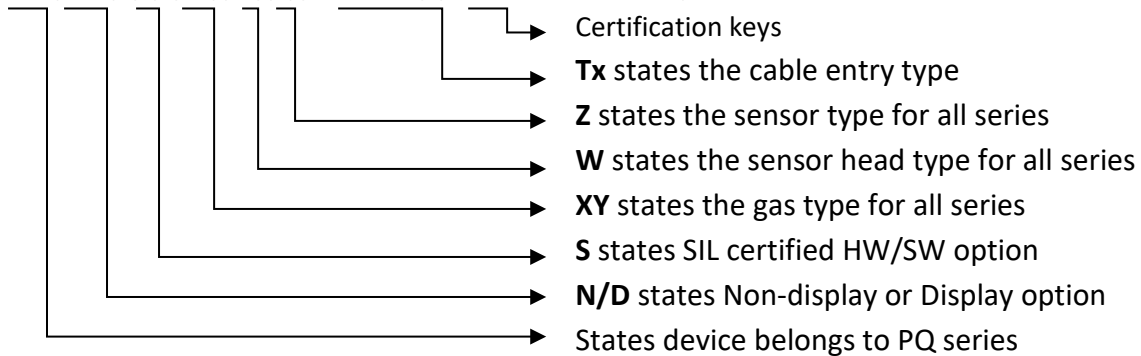

Model Options:

PQ Series Detector can be configured with or without display. Also PQ Series detector can be configured with functional safety certified HW and SW. These model names are given below in detail:

PQN Model : PQ Series detector enclosure without display

PQN series naming schema is “**PQN – ((XY) (W) (Z))(T1/T2/T3)”**

Key code: **PQN - ** 3* T***

PQD Model : PQ Series detector enclosure with display

PQN series naming schema is “**PQD - ((XY) (W) (Z))(T1/T2/T3)”**

Key code: **PQD - ** 3* T***

PQN-S Model : PQ Series detector enclosure without display with Functional Safety certified HW+SW

PQN series naming schema is “**PQN-S- ((XY) (W) (Z))(T1/T2/T3)”**

Key code: **PQN-S- ** 3* T***

PQD-S Model : PQ Series detector enclosure with display with Functional Safety certified HW+SW

PQN series naming schema is “**PQD-S- ((XY) (W) (Z))(T1/T2/T3)”**

Key code: **PQD-S- ** 3* T***

Cable Entry Type Options:

PQ Series detector enclosure has 4 entries. Entry-4 is reserved for sensor head. Other entries are for cable entries and the can be either in 1/2" NPT, 3/4" NPT or M20. Below table shows cable entry type configuration:

Type	Entry 1	Entry 2	Entry 3	Entry 4
TYPE 1	1/2" NPT	1/2" NPT	1/2" NPT	3/4" NPT
TYPE 2	3/4" NPT	3/4" NPT	3/4" NPT	3/4" NPT
TYPE 3	M20	M20	M20	3/4" NPT

Build and Certification Options:

PQ Series detector build by a detector enclosure and Prosense SH30 Sensor Head. The detector is certified in below configuration options:

- If there is no sign after cable entry type (Tx) the device is built as PQ enclosure and additional sensor head as separate device. This configuration is certified by **ExVeritas**

with **ATEX (ExVeritas 18ATEX0371X)**, **UKEX (EXV21UKEX0878X)** and **IECEX (IECEX EXV 18.0021X)** certificates.

- If there is C1 sign after cable entry type (Tx) the device is built as PQ enclosure and SH30 sensor head as complete and integrated single device. This configuration is certified by **UL with ATEX (UL 21 ATEX 2656X)**, **UKEX (UL22UKEX2376X)** and **IECEX (IECEX ULD 21.0033X)** certificates.
- If there is C2 sign after cable entry type (Tx) the device is built as PQ enclosure and SH30 sensor head as complete and integrated single device. This configuration is certified by **UL with UL** and CSA Ordinary and Hazardous Location standards (**E521536**).
- If there is C3 sign after cable entry type (Tx) the device is built as PQ enclosure and SH30 sensor head as complete and integrated single device. This configuration is certified by **UL with Brazil INMETRO standards (UL-BR 22.0598X)**.
- If there is C4 sign after cable entry type (Tx) the device is built as PQ enclosure and SH30 sensor head as complete and integrated single device. This configuration is certified by **UL with ECASEx standards (Certification No TBC)**.

Explosion-Proof Specification

ATEX (ExVeritas 18ATEX0371X)

II 2G
Ex db IIC T6 Gb
I M2
Ex db I Mb
Tamb -40°C to +70°C

IECEX (IECEX EXV 18.0021X)

Ex db IIC T6 Gb
Ex db I Mb
Tamb -40°C to +70°C

cULus/CSA

Class I, Division 1, Groups A, B, C and D
Zone 21, AEx tb IIIC T85°C Db, IP6X
Ex db IIC T6 Gb
Ex tb IIIC T85°C Db
Tamb -40 to +70°C, Temp Code T6

ATEX (UL 21 ATEX 2656X), UKEX (UL22UKEX2376X) and IECEX (IECEX ULD 21.0033X)

II 2G
Ex db IIC T6 Gb
Ex tb IIIC T85°C Db

INMETRO (UL-BR 22.0598X)

Ex db IIC T6 Gb
Ex tb IIIC T85°C Db
Tamb -40 to +70°C, Temp Code T6

Detector parts

Prosense PQD detectors comprises of the main parts as shown below:

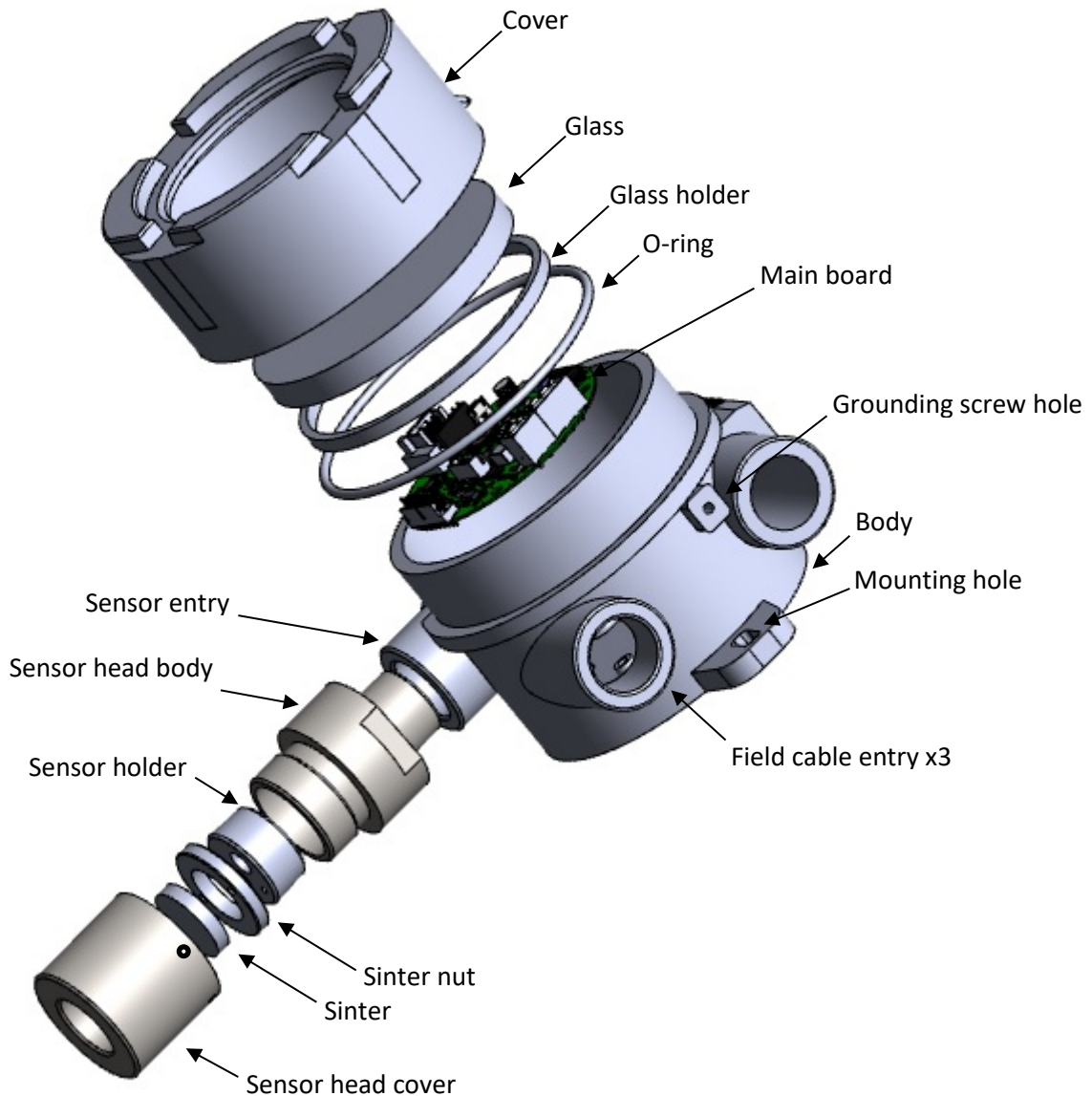

Diagram 2: Exploded view of PQD detector



ATEX/IECEx certified Sensor Head must be used in hazardous atmosphere.

According to the ATEX Directive 2014/34/EU, IECEx, UKEX standard rules the detector is an assembly consisting of three components (Sensor Head, enclosure and cable gland), where all these three components are type approved according to ATEX, IECEx and UKEX rules and marked by the device category II 2GD. The PQ series detector comprises a gas sensor type Ex-proof (protection type flameproof enclosure **db/tb** type). Thus this detector is suitable to be operated in hazardous areas with potentially explosive atmospheres of Zone 1/2 and Zone 21/22..

Detector body

The detector enclosure has four threaded entries. The two cable entries either side of the upper part of the transmitter housing are for connecting the power source, signal output and relay contacts to associated signalling equipment. The bottom entry allows direct connection of the sensor socket. There are two mounting holes incorporated into the transmitter housing.

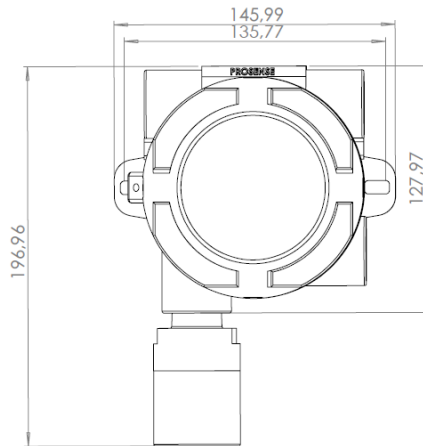

Diagram 3: Detector body and Sensor Head

Detector body has four entries and depending of the type selection their size and type will be different. The type information can be easily checked from the label as it mentioned with T code. For example, PQD-3135 T1 means the detector body uses TYPE 1 body. The entries shown in Diagram-4:

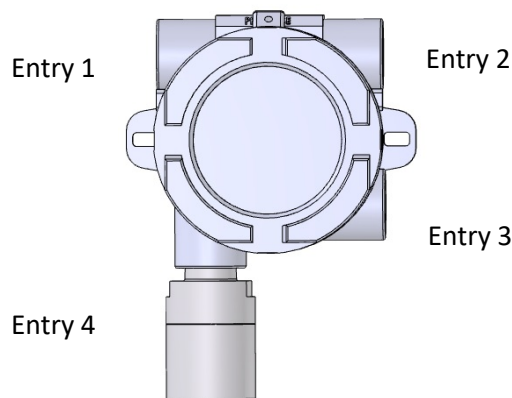

Diagram 4: Detector body cable entries

The entry specifications related to detector body are given in table-2 below:

Type	Entry 1	Entry 2	Entry 3	Entry 4
TYPE 1	1/2" NPT	1/2" NPT	1/2" NPT	3/4" NPT
TYPE 2	3/4" NPT	3/4" NPT	3/4" NPT	3/4" NPT
TYPE 3	M20	M20	M20	3/4" NPT

Table 2: Detector body types and entry specifications



Install wiring accessories and close all threaded entries in accordance with NFPA 70 for the marked hazardous location.

Sensor Head

The Prosense sensor head designed to detect flammable, toxic and oxygen gases. Sensor head may include Infrared, pellistor and a wide range of toxic gas sensors based on electrochemical cell (ECC) technology.

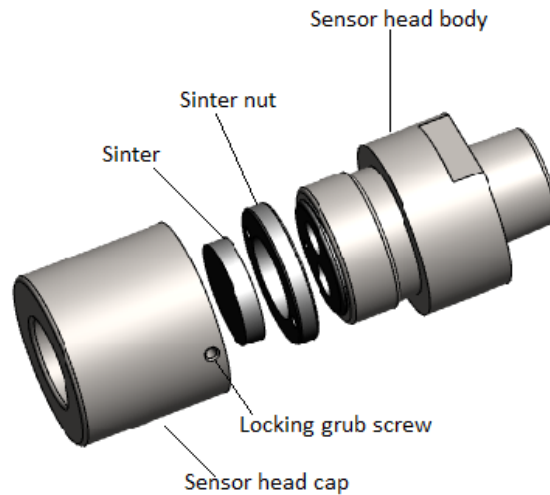

Diagram 5: Sensor Head components

Installation

Gas detectors should be mounted where a potential hazard of gas is most likely to be present. The following points should be noted when locating gas sensors.

- When locating detectors consider the possible damage caused by natural events e.g. rain or flooding.
- Consider ease of access to the gas detector for functional testing and servicing.
- Consider how escaping gas may behave due to natural or forced air currents.

Note: The placement of gas detectors should be determined following the advice of experts having specialist knowledge of gas dispersion, experts having knowledge of the process plant system and equipment involved safety and engineering personnel. The agreement reached on the location of detectors should be recorded.

Each gas has different nature depending on their density. The density of which is lower than air, such as hydrogen, methane or ammonia the sensor head must be located above a possible leak or at the highest points at which major concentrations of gas may be found. The gases and vapours with a density greater than air, the sensor head must be installed beneath a possible leak or at the lowest points at which such gases and vapours may be present.

Prosense may provide cable gland together with detector in regards to customer requests. The cable gland provided by Prosense has ATEX/IECEx/UKEX/UL certification and provides at least IP65 level protection. The cable glands are only suitable for fixed installations. Cable gland body should be fixed to related entry with 20Nm torque. Cables shall be effectively clamped to prevent pulling or twisting. To provide necessary protection cable gland coupling should be fixed with 20Nm torque when used with three sealing; 18Nm when used with two

sealing; 16Nm when used with one sealing. It is the final assemblers'/users responsibility to ensure the threaded joint between cable gland and the enclosure meet all the requirements of the applicable standards for the assembly. Cable gland sealing are suitable for the circular type cables. If other shaped cables will be used the sealing should be replaced with suitable ones. The cable glands provided by Prosense are suitable to use temperature range in which detector works.

Prosense may provide plugs and adaptors together with detector in regard to customer requests. The plugs and adaptors provided by Prosense have ATEX/IECEX/UKEX/UL certification and provide at least IP65 level protection. These parts should be mounted to detector body in such a way that accidental rotation or loosening will be prevented. Plug should be fixed to related entry with 20Nm torque. It is the final assemblers'/users responsibility to ensure the threaded joint between fitting and the enclosure meet all the requirements of the applicable standards for the assembly. For adaptors and plugs with nominal size of thread equal or lower than 25 mm aluminium alloy shall not be used. Only one adaptor permitted for each cable entry; plugs shall not be used with adaptors. The plugs and adaptors provided by Prosense are suitable to use temperature range in which detector works.

The user-supplied cable gland, plug and adaptor must be ATEX/IECEX/UKEX/UL certified. Components that do not have ATEX/IECEX/UKEX/UL certificate cannot be used.

WARNING



All entries must contain appropriately rated plugs or fittings. It is required that each plug or fitting be wrench-tightened to an appropriate installation torque and meet the minimum thread engagement requirements per the applicable local standards, codes, and practices in order to retain the defined ratings.

Mounting the detector

The detector must be mounted vertically as the sensor head pointing downwards. Detector has to be mounted such that the sensor's gas entrance area. The install location

- should be isolated from vibration, direct sun light and have temperature stability
- avoided external influences such as splashing water, oil, corrosive aerosols
- should have at least 30 cm free space beneath the sensor head to provide accessibility for calibration work.
- should be in air flow between possible leak or collection point and possible source of ignition.

Prosense do not recommend installing detectors to:

- directly above a cooking unit,
- directly above a sink unit,
- close to an extractor unit,
- outdoor without protection against the rain,
- in places where temperature is outside the admissible operating range,
- corrosive environments,
- inside air vents.
- environments where silicon can be found.

Prosense PQ series detector has mounting two mounting holes on detector body to fix detector directly to a surface:

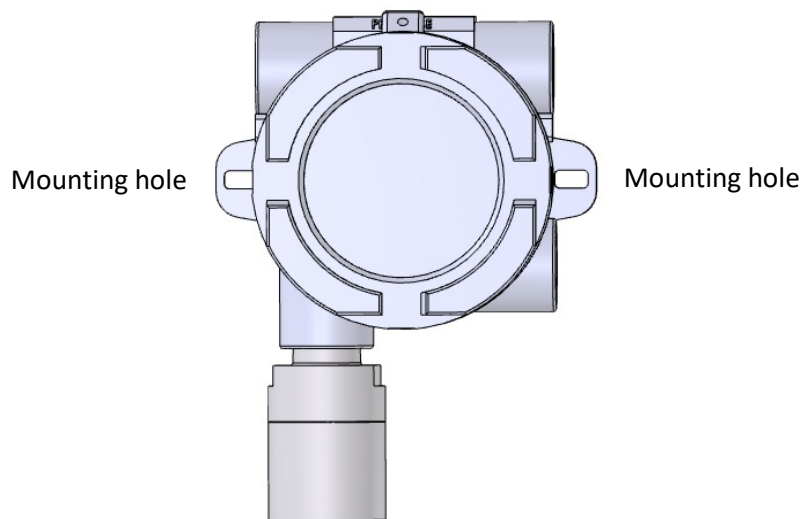

Diagram 6: Mounting holes

Electrical connections

CAUTION

The wiring procedures in this manual are intended to ensure proper functioning of the device under normal conditions. However, because of the many variations in wiring codes and regulations, total compliance to these ordinances cannot be guaranteed. Be certain that all wiring complies with the NEC as well as all local ordinances. If in doubt, consult the authority having jurisdiction before wiring the system. Installation must be done by a properly trained person.

CAUTION

Observe precautions for handling electrostatic sensitive devices.

PQ Series Detector must be powered by a SELV power supply.

The PQ Series Detector shall be supplied by an isolated power source which fulfils the requirements of:

- Limited-Energy Circuit in accordance with UL/CSA 61010-1,
- Limited Power Source (LPS) in accordance with (UL/CSA 60950-1 or EN 62368-1, Annex Q) or
- Class 2 supply source which complies with the National Electrical Code (NEC), NFPA 70, Clause 725.121 and Canadian Electrical Code (CEC), Part I, C22.1.

Prosense detectors can operate between 12 - 24 VDC. The connection socket located on main board as given in Diagram-11 (page 19) and details given in below table 2:

Output	Usage
V +	Power input (+) 12VDC – 24VDC
V -	Power input (-) 12VDC – 24VDC
S	Current Output Signal (4mA – 20mA)

Table 3: Detector output ports and their usage

The detector designed to give 4 - 20 mA current output signal. It is also possible to get voltage value via using an additional resistor. Below Table-3 gives recommended resistor specifications to get correct voltage output from detector depending of the desired signal level:

Detector Power VDC	Resistor	Signal level (4mA – 20mA)
12 VDC – 24 VDC	250 Ω, tolerance %1	1 VDC – 5 VDC
12 VDC – 24 VDC	500 Ω, tolerance %0,1	2 VDC – 10 VDC

Table 4: Detector power and the output resistor

Please consider the cable length when performing installation in the field. The Prosense detector requires a power supply between 12VDC and 24VDC. Make sure that a minimum 12 VDC supply available at the detector entrance and consider the voltage drop due to cable

resistance in case of long-distance applications. The maximum loop resistance in the field cable is calculated as follows:

$$R_{loop} = (V_{controller} - V_{detector\ min}) / I_{detector}$$

Example;

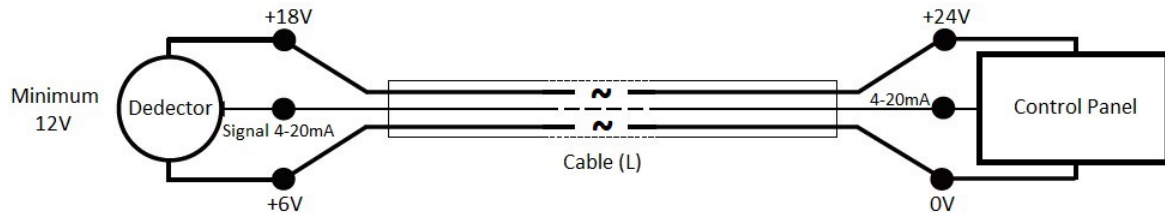

Diagram 7: Field cabling

The controller or power supply is supplying a nominal 24VDC ($V_{controller}$), the detector minimum allowable voltage is 12VDC ($V_{detector\ min}$), therefore the maximum allowable voltage drop between the controller and detector is 12VDC; this means a voltage drop of 6V in each core ($V+$ core and $V-$ core).

Minimum power consumption of the detector without any optional module is 1W. The current required to drive the detector at the minimum voltage is ($I = P / V$) : $1.0 / 12 = 85\text{mA}$ ($I_{detector}$).

Maximum power consumption of the detector when optional relay modules installed and all relays are active is 4.0W. The current required to drive the detector at the minimum voltage is ($I = P / V$) : $4.0 / 12 = 335\text{ mA}$ ($I_{detector}$).

So, the maximum field cable loop resistance (R_{loop}) = $12 / 0.335 = 36\text{ Ohms}$, or 18 Ohms per core, (allowing for component variations, losses, etc.).

The following tables show the maximum cable distances between the controller and transmitter assuming a voltage drop of 6V in each core and for different cable parameters. The tables are examples only and actual cable parameters and source power supply voltage for the application should be used to calculate the maximum cable distance allowed at the installation site.

Typical cable data for detector with relay module given in Table-4:

Cable size (cross sectional area)	Cable type nearest equivalent	Cable resistance Ω/km	Maximum Cable length (L) Meters
0.5mm ²	20AWG	36.8 Ω/km	~400
1.0mm ²	17AWG	19.5 Ω/km	~700
1.5mm ²	16AWG	12.7 Ω/km	~1100
2.0mm ²	14AWG	10.1 Ω/km	~1400
2.5mm ²	13AWG	8.0 Ω/km	~1800

Table 5: Typical cable details and maximum distance for cabling

Cabling

The use of industrial grade, suitably shielded field cable is recommended. The best practices shown that, screened 3 cores (plus screen 90% coverage), suitably mechanically protected copper cable with a suitable explosion-proof gland, or ¾" NPT steel conduit, depending on the distance between signal received or control panel and detector 0.5 to 2.5 mm² (20 to 13 AWG) conductors can give better results. Ensure the cable gland is installed correctly and fully tightened.



WARNING

Cable used with device must be suitable for at least 90°C and cable entry devices suitable for at least 75°C.

Cable and Earth/Ground regimes

Effective Earth/Ground bonding is important to ensure good EMC and RFI immunity. The following diagram show example of how to earth/ground bond the cable at enclosures. The same principles apply to conduit installations. These bonding techniques provide good RFI/EMC performance. Earth/ground loops must be avoided to prevent the risk of false signal variation.

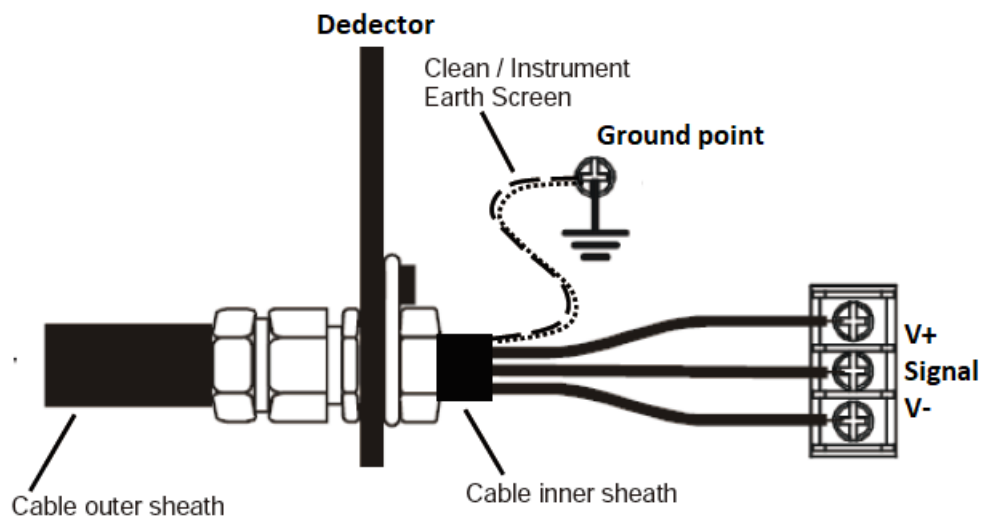

Diagram 8: Grounding

The Earth Screen of the field cable should be “tied to Earth” or connected to Ground at one point only. It is common practise to adopt a STAR EARTH connection regime where all instrumentation Screens are connected at one common point. The Screen at the other end of the cable should be “parked” or terminated into a blank terminal.



Internal grounding terminal shall be used as the equipment grounding means and the external terminal is only a supplemental bonding connection where local authorities permit or require such a connection.

Detector grounding

Internal Ground connection: Each detector has grounding screw which utilizes grounding for detector main PCB to detector body. The screw should be located correctly and fixed for all times. In case of any maintenance activity this screw should be checked and fixed to make sure for proper grounding.

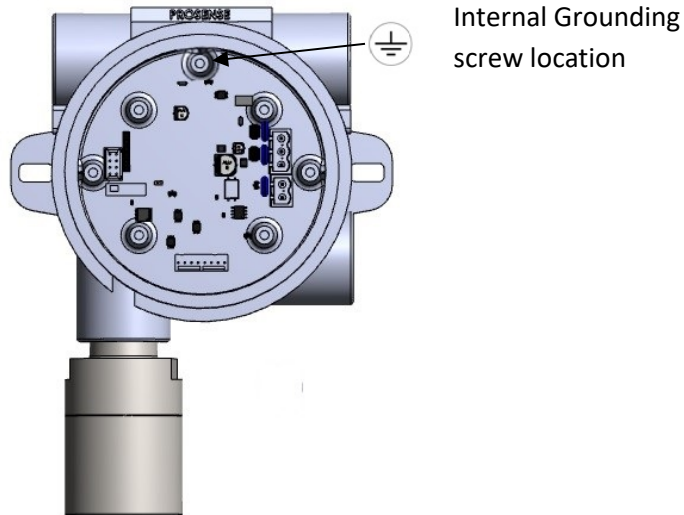

Diagram 9: Detector internal grounding screw location

Internal grounding screw location should be reserved for grounding cable and not used for any other purpose.



For Hazardous Location installation, minimum internal earth size must at least equal the incoming conductor size (i.e 1.5mm² live/neutral = minimum of 1.5mm² earth too).

External Ground Connection: The detector body has two grounding locations as shown in Diagram-9. It is recommended to utilize a No 14 AWG copper, (Stranded or Solid), wire.

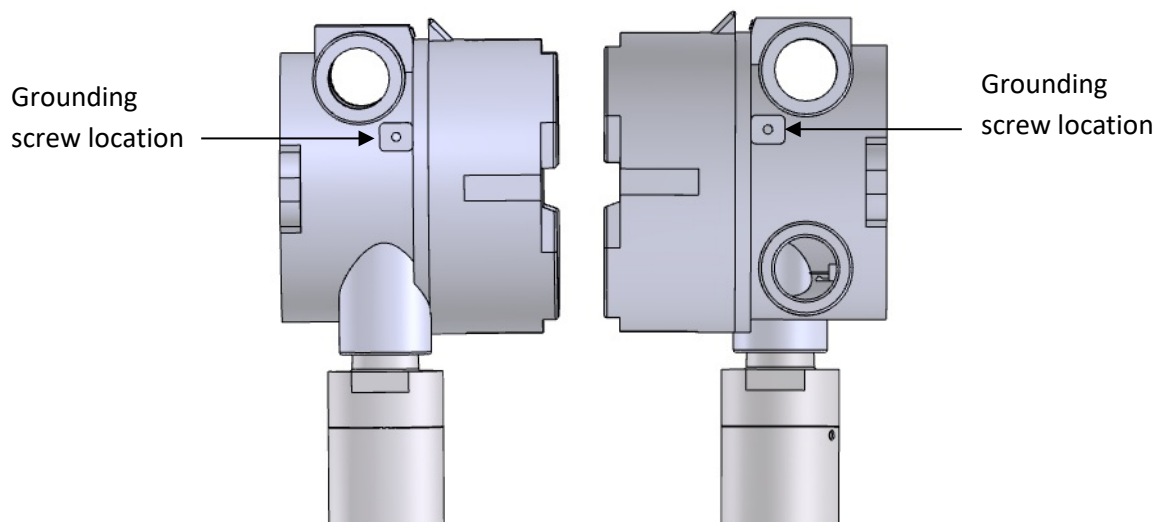

Diagram 10: Detector grounding locations

PQ Series Detector Configuration

PQ series detectors able to provide 4-20mA analogue output, MODBUS RTU Serial Output, HART output and Switching output based on their configuration. The Prosense PQ detector has 4-20mA analogue output and RS485 Modbus serial communication output features on main board. It is possible to install optional relay module to have three relay outputs for two adjustable alarm levels and fault status. Also HART output is available with optional HART module. The main board connection pins are explained in Diagram-11:

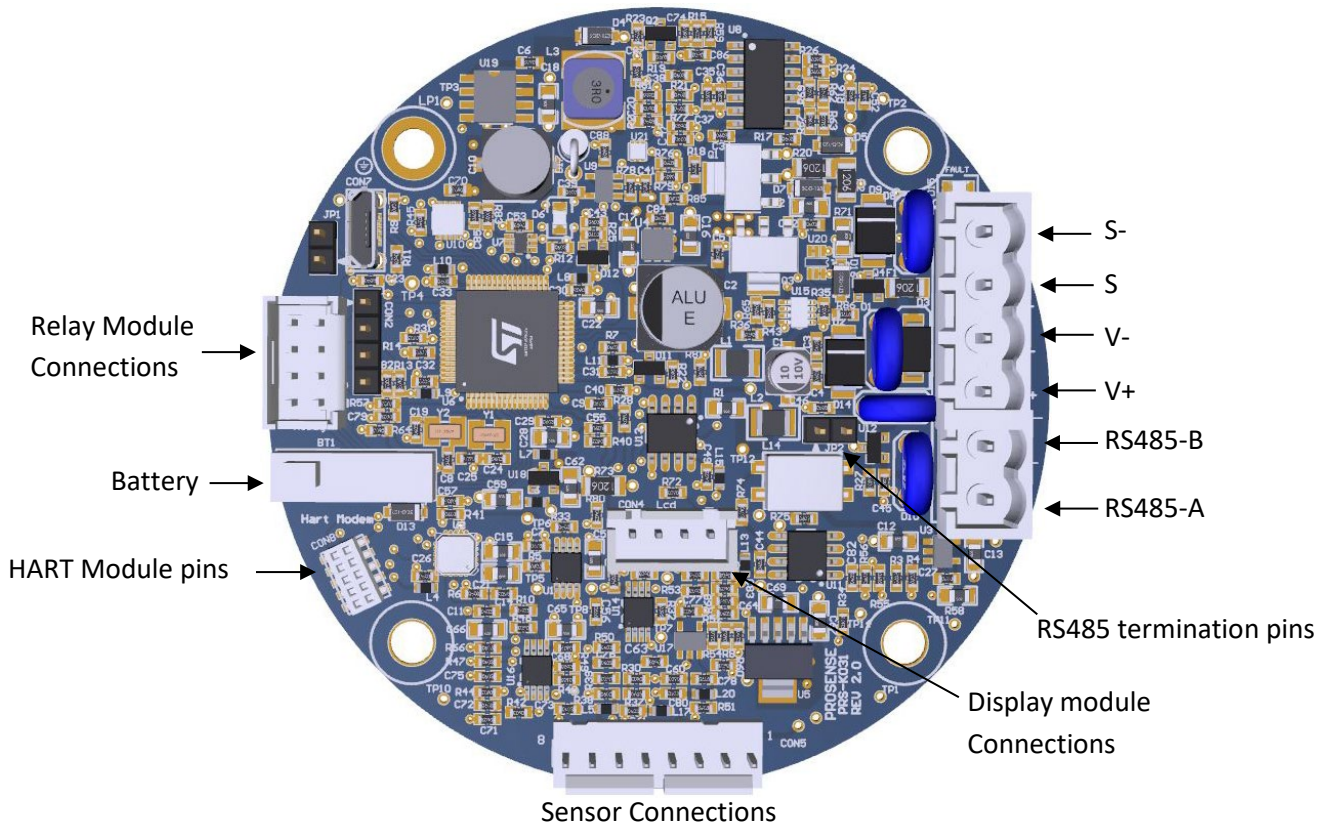

Diagram 11: Detector main board and connections

Sensor connections are input to detector main board and already connected to sensor inside the sensor head. Detector connections are listed in Table-6:

Port	Usage
V +	Power input (+) 14VDC – 28VDC
V -	Power input (-) 14VDC – 28VDC
S	Current Output Signal (4mA – 20mA)
S-	Current Output Signal (4mA – 20mA)
RS485-A	Serial connection port A
RS485-B	Serial connection port B

Table 6: Detector output ports and their usage

4-20 mA output:

The default configuration provides single 4-20mA signal output. Prosense detectors can be connected to control panels on the market having 4-20mA input signal. Analogue output signal should be taken from S+ pin. Signal wiring needs 3 wires as V+ and V- to provide power to detector and S+ to read output signal from detector. Signal wiring from detector

and the control panel should be carried out by shielded cables. Wires cross section depends on the distance between the control panel and the detector. The details given in power cabling are valid as well for signal output. We recommend using values given in Table-4 as cabling best practices.

The current level can be used to define special states. These levels are adjustable in predefined ranges. The default signal levels are given in Table-XX:

Function	Value/Setting	Meaning
Signal output	2.0 mA	Fault
	2.0 mA to 3 mA	Warm-up
	3mA	Calibration mode
	4.0 mA to 20.0 mA	Normal gas measurement
	21.0 – 22.0 mA	Over range

Table 7: Detector default configuration details

Please avoid any interruption in case any junctions on wires. The shield is to be grounded from the control panel side only and never connect the shield to the detector. Please make sure clenching or crimping apparatus are not loosened or oxidized.

To get the analogue output signal correctly and constant, the load resistor between S and S-ports should be between 100-500 Ohms. If the load on S ports drops below 100 Ohms the detector decides the output was in short circuited and enables the automatic output saving mode resulting with reducing signal level to 2mA. . If the analog current output is not to be used, the 120 Ohm resistor sent with the detector must be inserted between the V- and S ports. Otherwise, the detector will display a current output error.

RS485 serial communication output:

Prosense PQ series detector has RS485 serial communication output on main board. The MODBUS communication is not part of functional safety. But can be used when needed. Connection ports are located on a different socket nearby analogue output and power input ports. User should prepare two wire additional cables when RS485 communication used. To use the detector with RS485 serial communication, a four-wire connection should be done which are energy input (V +, V-) ports and RS485 (A, B) ports. Even if only the RS485 connection is to be used, the S end must have the required load resistance. If both analog current output and RS485 serial communication terminals are to be used at the same time, a five-wire connection must be made to connect the terminals on both sockets (V +, V-, S, A, B). The total length of the connection line should not exceed 800 meters. The wiring for detectors utilized with RS485 board should be done by using connection cable EIA RS485 2 core wires with section 0.22 / 0.35 mm² and shielded. Nominal capacity between the wires should be < 50pF/m and nominal impedance 120 Ohms.

Detectors will be wired in daisy chain (bus) mode. We recommend not using star mode connection due to negative impact of interference. Each detector should have unique address number in the chain. The detectors would not be recognised by control panel if same address given to them. The address of detector can be adjusted via using configuration

hand module or display. Detectors can be assigned to use addresses from 1 to 247 (including 247). Address zero (0) cannot be used by detectors.

The last detector in the chain should have 120 Ohms RS485 termination resistor. The resistor is already implemented on the board by default but not activated. User should activate the termination resistor via using the RS485 termination pin shown on Diagram-11 once the installation completed.

Relay module:

Prosense provides optional relay modules for Prosense PQ detectors. The relay module details are given below:

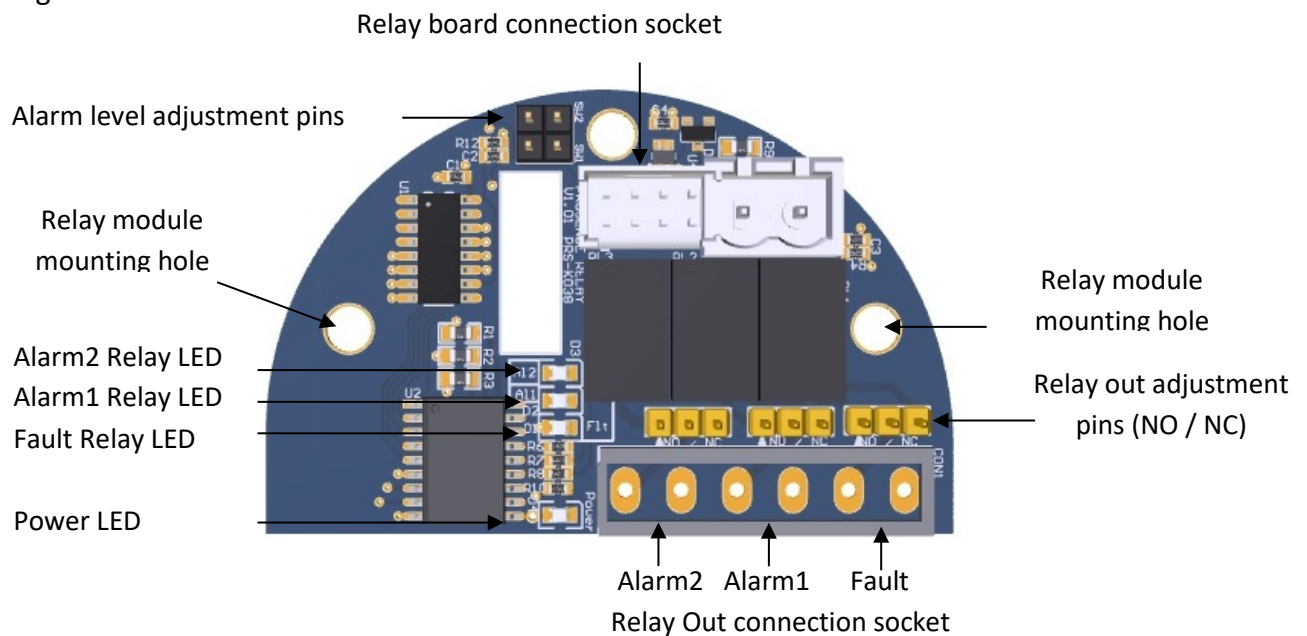

Diagram 12: Relay module

The relay board has 3 relay outputs:

Port	Usage	Energy	Contact (NO / NC)
Fault	Fault Relay output	Energised	NO
AL1	Alarm 1 Relay output	Non-Energised	NO
AL2	Alarm 2 Relay output	Non-energised	NO

Table 8: Relay module output ports

Each relay has 3 pins grouped on board to adjust how to behave in case of alarm which are

NO: Normally Open

NC: Normally Close

The relay output pin positions shown below:

	Normally Open (NO)
	Normally Close (NC)

Table 9: Relay output pin positions

The relay module set to NO (Normally Open – De-Energised) position at factory. The Fault relay is set to NO (Normally Open – Energised). It will be de-energized in case of power failure. This helps user to easily identify any power outage on detector side.

The alarm levels are also adjustable via using SW1 and SW2 alarm level pins. Alarm levels are defined as percentage in LEL for flammable gases. The alarm levels can be adjusted using jumpers to switch SW1 and SW2. Possible options are given in table-9:

SW1	SW2	AI1 Level (LEL or PPM)	AI2 Level (LEL or PPM)
Open*	Open*	10 %	15 %
Open	Closed	10 %	20 %
Closed	Closed	20 %	25 %
Closed	Open	20 %	40 %

*: Default

Table 10: Alarm level pin positions (for % LEL or % PPM)

Alarm levels can be adjusted via user menu in PQD models. These settings will overwrite to SW1 and SW2 settings.

Oxygen detectors:

For oxygen detectors the output values and meanings are different as oxygen is naturally available in atmosphere:

Port	Usage
Fault	Fault Relay output
AL1	Alarm 1 Relay output - Lower level for Oxygen
AL2	Alarm 2 Relay output - Higher level for Oxygen

Table 11: Relay module output meanings for Oxygen detectors

Alarm levels are also different as given in below table:

SW1	SW2	AI1 Level	AI2 Level
Open*	Open*	19 %vol	23 %vol
Open	Closed	19 %vol	22 %vol
Closed	Closed	18 %vol	22 %vol
Closed	Open	18 %vol	23 %vol

*: Default

Table 12: Alarm level (% Vol) pin positions for Oxygen detectors

In PQD model detectors, alarm levels and relay outputs can be set to the desired value except for lower or upper-level definitions given for oxygen. Both alarm levels can be used for decreasing or increasing values.

HART Module

Prosense is a HART registered product manufacturer. The analogue signal output has two pins to utilize HART communication. Prosense HART Module must be installed on to transmitter to enable HART communication. PQ series transmitter has a special 10-pin socket to connect HART Modem.

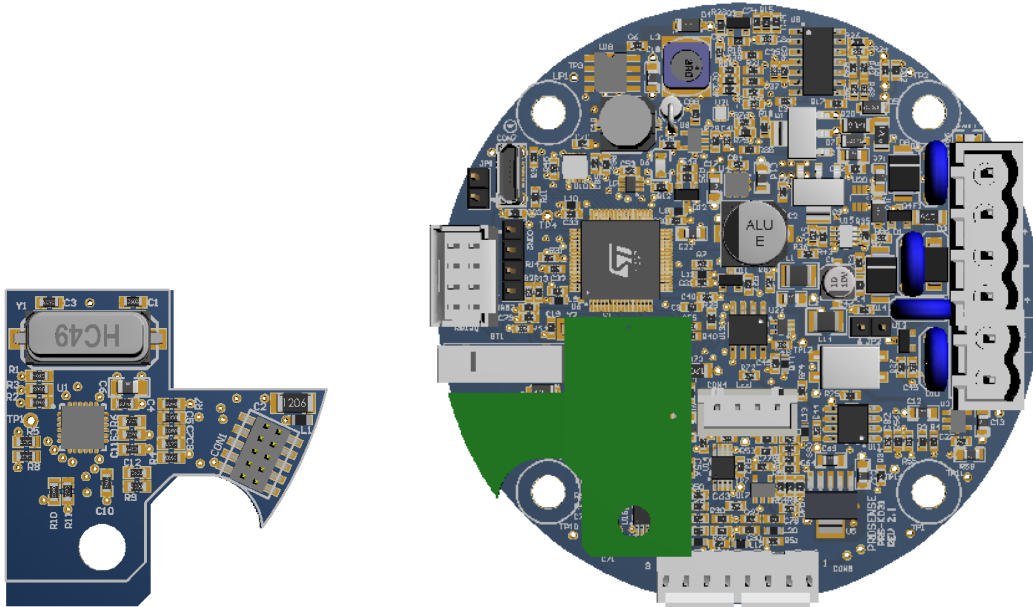

Diagram 13: HART module and mainboard with HART module

HART signal can be gathered from detector via counting to S+ and S- ports. Two pins connection is mandatory to get HART output as there needs to be a frequency key shifting (FSK) mechanism. Prosense HART interface uses below parameters:

Manufacturer Name	Prosense
Manufacturer ID Code	0x6154
HART Protocol Revision	7.7
Number of Device Variables	4
Physical Layers Supported	FSK
Physical Device Category	Current output (4-20mA) / Maintenance port (Local)
Model Name	PQ Series
Device Type Code	0xE541
Device Revision	1

Table 13: Prosense HART Parameters

Please use HART Field Device Specification document for detailed implementation.

System Status

The Prosense PQ detector has a screen to show status messages and measurement levels online. Also it has five LEDs to show power, fault, alarm1, alarm2 and alarm3 status. If equipment is in normal condition the green power LED will lit and screen will show the gas that detector measuring, current level of gas detector reading, data and time information, ambient temperature and a bar to show level of current gas measurement.

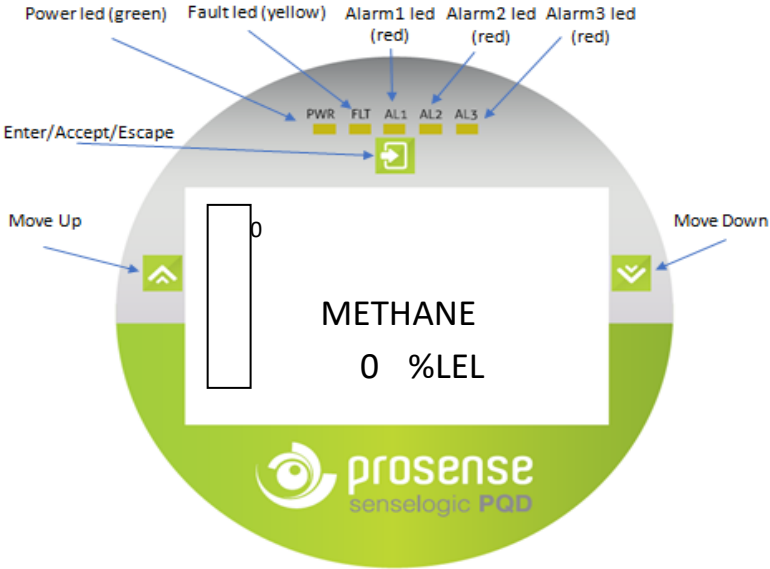

Diagram 14: PQ Series Detector Display and LEDs

Default display screen is used to show gas level as a text and bar graph, detector state and subsidiary messages such as alarm 1 or over range fault. The detector special state messages and related LED status for each special state are also shown;

PQ Series Visual Indications						
Status	Message	PWR (Green)	FLT (Yellow)	AL1 (Red)	AL2 (Red)	AL3 (Red)
Power-off	_					
Warm-up	Warm-up	Solid Green	Flashing Yellow			
Normal	Normal	Solid Green				
Fault	Fault	Solid Green	Flashing Yellow			
Calibration	Calibration	Solid Green	Flashing Yellow			
Underrange	Fault	Solid Green	Flashing Yellow			
Alarm 1	Alarm 1	Solid Green		Solid Red		
Alarm 2	Alarm 2	Solid Green		Solid Red	Solid Red	
Alarm 3	Alarm 3	Solid Green		Solid Red	Solid Red	Solid Red
Overrange	Overrange	Solid Green	Flashing Yellow	Solid Red	Solid Red	Solid Red

Table 14: PQ Series visual indications

Indication of measured values

Display screen shows the concentration level of the target gas in two ways. In the first, a numeric value is shown in the middle of the display in the units selected (PPM, %LEL, %VOL). The second concentration display is shown in the form of a bar graph representing the current concentration against full scale and in relation to the defined alarm levels.

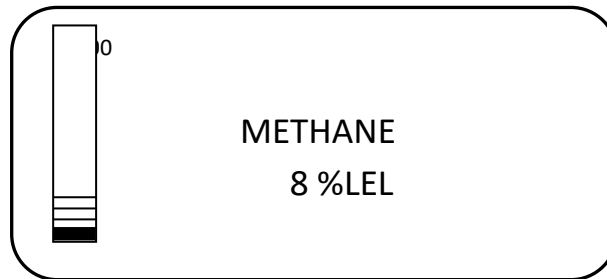

Warmup

The detector will need to warm-up to be ready when power applied. Warm-Up period takes 1 minute and during this time WARMUP status messages shown on upper right side of the screen. Also Fault LED will be lit.

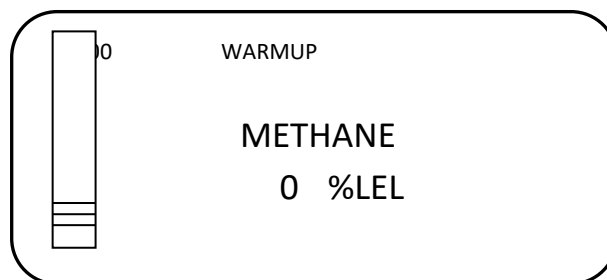

User must wait till end of the warm-up period to see actual status of the detector.

Fault

If detector is in fault condition Fault LED will be lit, screen show fault message and the detector analogue output gives 2mA on S port. If detector could not get enough power (lower than 12 VDC) it will also raise fault status.

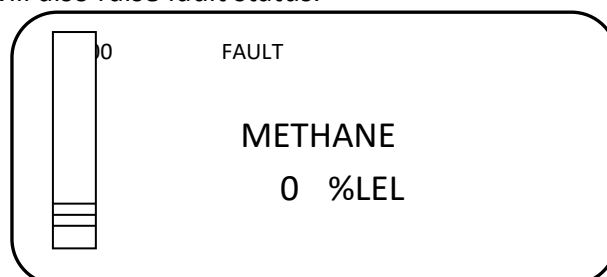

Detector also provides key information about fault reason and details. They are listed at Fault status codes section.

Alarm

Equipment has LED indication on the display module for alarm levels which are Alarm-1, Alarm-2 and Alarm-3. The Alarm-1 and Alarm-2 is integrated to relay module and equipment can provide switching output for defined alarm levels. Alarm-3 is only visual alarm and it is

not integrated to relay module. Hence it is not possible to get switching output for Alarm-3. In case of an alarm, related alarm LED will lit and alarm information will be shown on the screen:

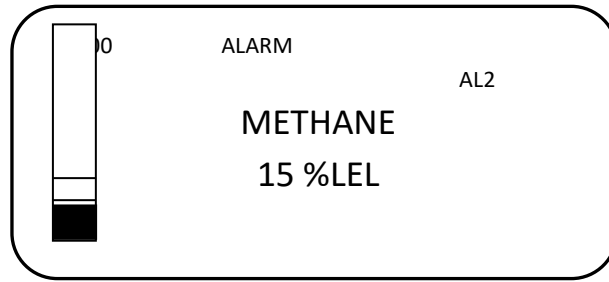

Calibration

Equipment shows countdown messages during the calibration. Equipment shows calibration message on display only in case user exited from menu during the calibration:

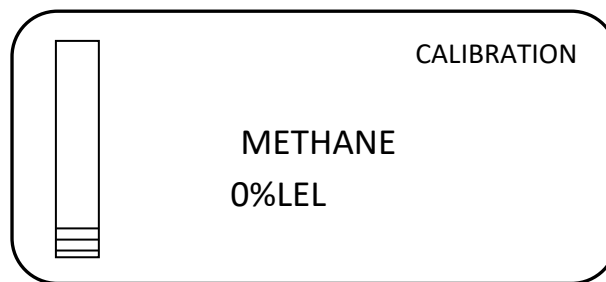

Underrange

Equipment detects underrange condition and set fault state where Fault LED will be lit, screen show fault message and the detector analogue output gives 2mA.

Overrange

Equipment provides overrange condition in case the measured gas level over the measurement range. All Alarm LEDs and Fault LED will be lit, screen show Overrange message and the detector analogue output gives 22mA. Overrange status on RS485 MODBUS output. If relay module is installed all relays Fault, Alarm-1 and Alarm-2 will be activated. The status will not change without user intervention even the gas concentration returns to normal level. It is necessary to power-cycle detector to reset status by user intervention.

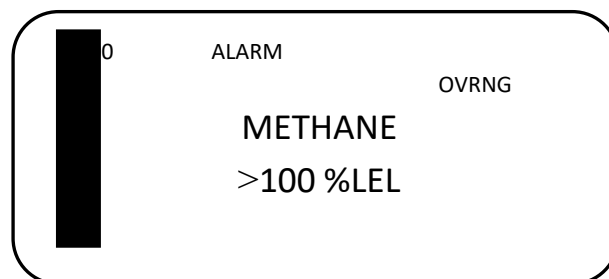

When user reset detector after environmental conditions return to normal, detector will perform all self-test and hardware test steps following reset. User can see detector status after reset. If detector returns to normal no additional step is required.

Commissioning

WARNING

The following procedure requires the detector cover to be removed while carrying out supply voltage checks. Therefore, the appropriate permits to work should be sought in preparation.

Prior to carrying out any HOT WORK ensure local security and site procedures are followed. Ensure that the associated control panel output actuation is inhibited so as to prevent false alarms.

Caution: The following procedure should be followed carefully and only performed by suitably trained personnel

Commissioning PQD/PQD-S

1. Remove the detector cover. Gently remove the display board from its location.
2. Configure the detector's analogue output signal and power input connections correctly
3. Check that all electrical connections are terminated correctly
4. Switch On the external power supply to feed the detector
5. Using a Digital Multi Meter (DMM), check the Supply Voltage at the terminals V+ (24V) and V- (0V), this should be a minimum supply voltage of 12VDC (Maximum supply voltage is 24VDC)
6. Check LED status on detector main board. LED will be illuminated right after applying power.
7. Check the screen. It will run self check tests and report the results. All tests should end with OK. In case of any ERROR message contact Prosense.
8. When test completed the screen will show monitoring screen with detector information and WARMUP message on status line. The Fault LED is lit in this period.
9. Wait two minutes to see WARMUP message removed from status line and fault LED gone off.
10. Switch Off the external power to the detector.
11. Fix the screen board to its location. Fit the cover and make sure none of the cables cause an obstruction while fitting cover. Fix the cover locking grub.
12. Switch on external power to the detector.

Commissioning PQN / PQN-S

1. Remove the detector cover
2. Configure the detector's analogue output signal and power input connections correctly
3. Check that all electrical connections are terminated correctly
4. Switch On the external power supply to feed the detector
5. Using a Digital Multi Meter (DMM), check the Supply Voltage at the terminals V+ (24V) and V- (0V), this should be a minimum supply voltage of 12VDC (Maximum supply voltage is 24VDC)
6. Check LED status on detector main board. LED will be illuminated right after applying power.
7. LED will start blinking twice in a second during the warm-up period and analogue output signal will provide 3mA.
8. Wait two minutes to complete warm-up period. The LED on main board will switch blinking once in a second and analogue output signal will be 4mA.
9. Switch Off the external power to the detector.
10. Fit the cover and make sure none of the cables cause an obstruction while fitting cover. Fix the cover locking grub.
11. Switch on external power to the detector.

Detector Settings

Prosense PQ detector prepared at factory to work as standalone detector. User may want to change settings and alarm levels depending of the usage. PQD detector screen can be used to change the detector settings. A magnet provided with detector to perform detector configuration changes. The 3 keys on display will be used to perform any operation which are Enter, up (Increase) and down (decrease). The Enter key needs longer touch (2 seconds) with magnet while up and down keys can operate 1 second touch. If user wants to cancel any operation on any screen keep magnet on Enter key till the screen return back to previous screen.

PQN Series detectors will have same functions, options and screens when used with a hand terminal. The hand terminal provided by Prosense and can be used to setup or maintain the detector.

Entering the menu:

To reach configuration menu press Enter. The screen will request password information:

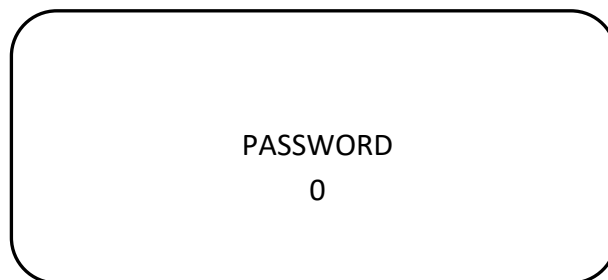

The password is 1234. User need to change the password as defined in “Change password” step. You need to set values via using up and down keys. Once the value is set press Enter again to confirm and move to the next digit. Confirmed digits will be made invisible by detector program:



The screen will display menu options when correct password entered at last digit:

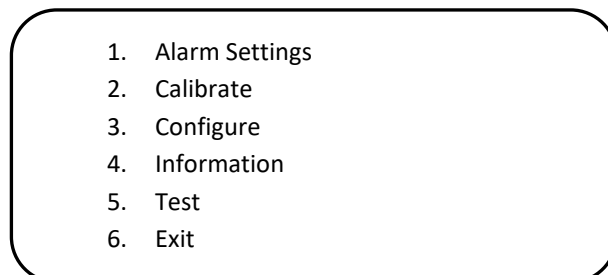

Menu structure

PQ Series Detector menu includes all necessary steps to setup detector and display information. Menu is available for only PQD and PQD-S models as they have display module.

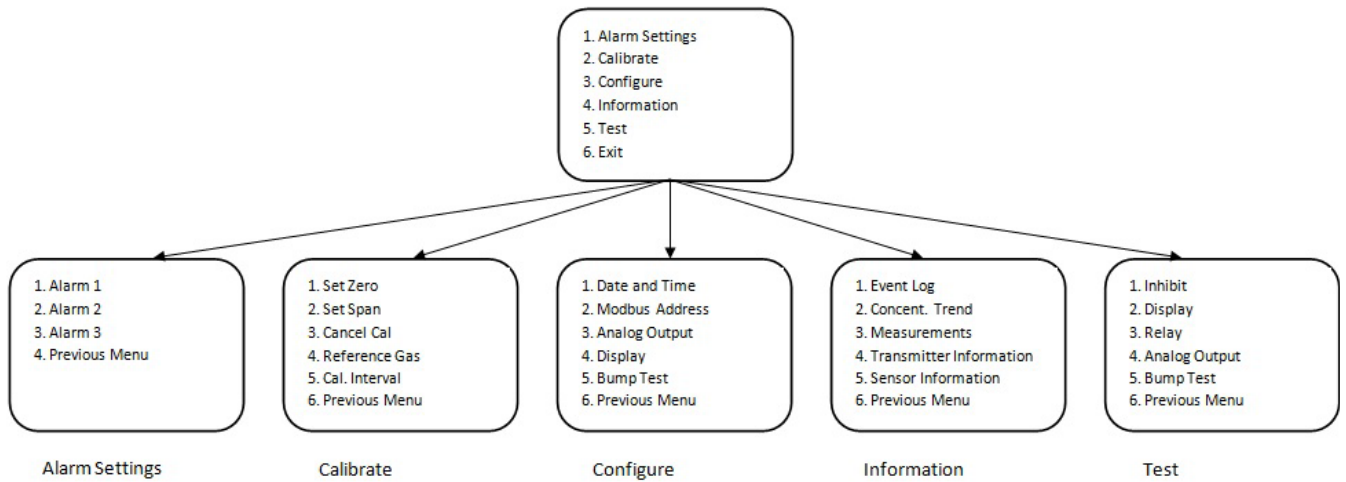

Diagram 15: Main menu structure

Alarm Settings

Alarm levels can be adjusted via using alarm menu steps. Alarm menu general structure is given in diagram-12:

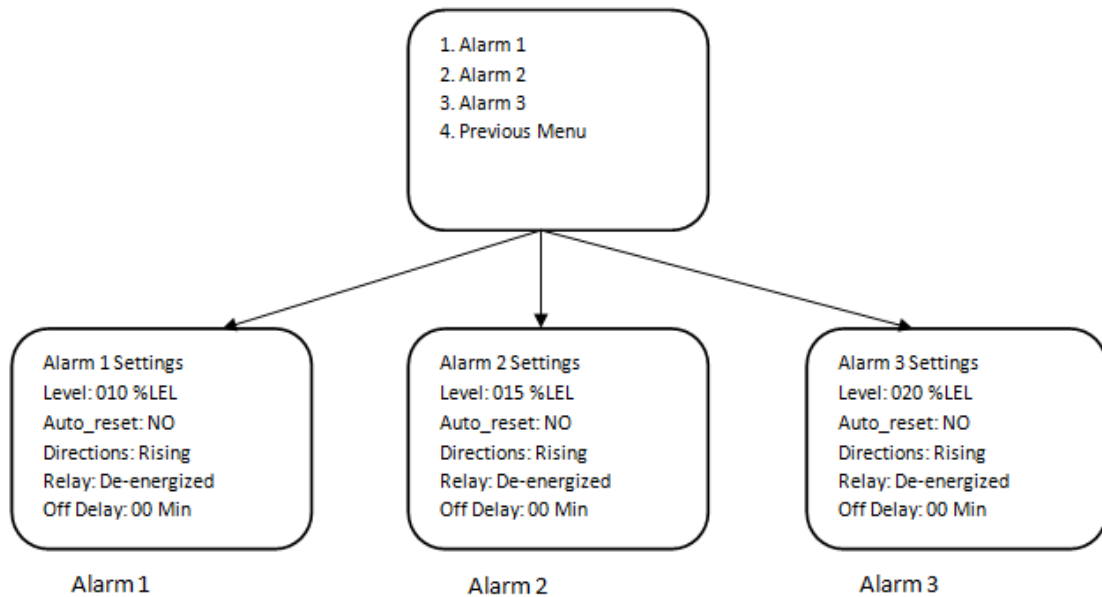
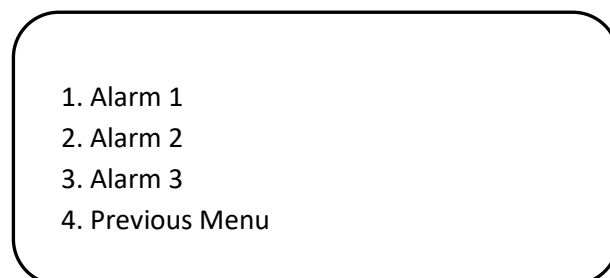
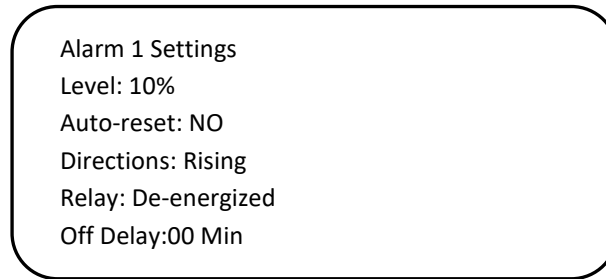

Diagram 16: Alarm menu structure

Once you reach the main menu the first option is alarm settings. Press Enter to move the alarm settings menu. A new menu listing alarm levels will be shown:



Please select the alarm level you would like to adjust and press Enter key to see details. All alarm details will be listed in new screen and parameters will be blinking one by one while you set the values.



The first digit of the first alarm will start blinking to let you increase or decrease the digit via using up and down keys. When you set the value, press again Enter key to move next digit. The next digit will start blinking to allow you set desired value. When you complete, press Enter key long enough. The display will show “Successful” message and return back to higher level menu.

All alarm levels have same parameter that user can adjust if needed. Otherwise they will work with their default settings. The meaning of parameters is as follows:

Level: The measurement level to raise the alarm

Auto-reset: Define how the alarm relays will work. If ‘YES’ selected the relay will be released once the measurement level returned to normal. If ‘NO’ selected the relay will lock in their position. According to IEC EN 60079-29-1 high level alarm “Alarm-2” is set to latch mode without auto-reset.

Directions: Parameter to define in which way alarm will be activated whether increasing or decreasing. For most toxic and flammable gases it will be raising, for oxygen it can be both raising and falling.

Relay: It defines the alarm relay working conditions. Relays can be programmed as Energised (NC) or Non-energized (NO) contact according to use cases and scenarios. When Energized is selected, the relay will have energy during normal operation. When Non-energized is selected, the relay is only energized when performing the switching function.

Off Delay: User can define delay to deactivate the alarms. Equipment keeps alarms and relay contacts active after measured gas level goes below the defined alarm level. This function must be adjusted according to operating conditions and safety rules. For example, in some plants ventilation fans kept activated after the measurement level falls below the alarm level. In such cases the off delay feature can be used. The off-delay can only be defined in minutes.

Configure

User can change the parameters of detector depending of the usage such as date, time, password and detector address via configure menu. Select 'Configure' step on main menu to perform changes. A new menu options will display with options:

- 1. Date and Time
- 2. Modbus Address
- 3. Analog Output
- 4. Display
- 5. Bump Test
- 6. Previous Menu

The Configure menu structure is given in below diagram:

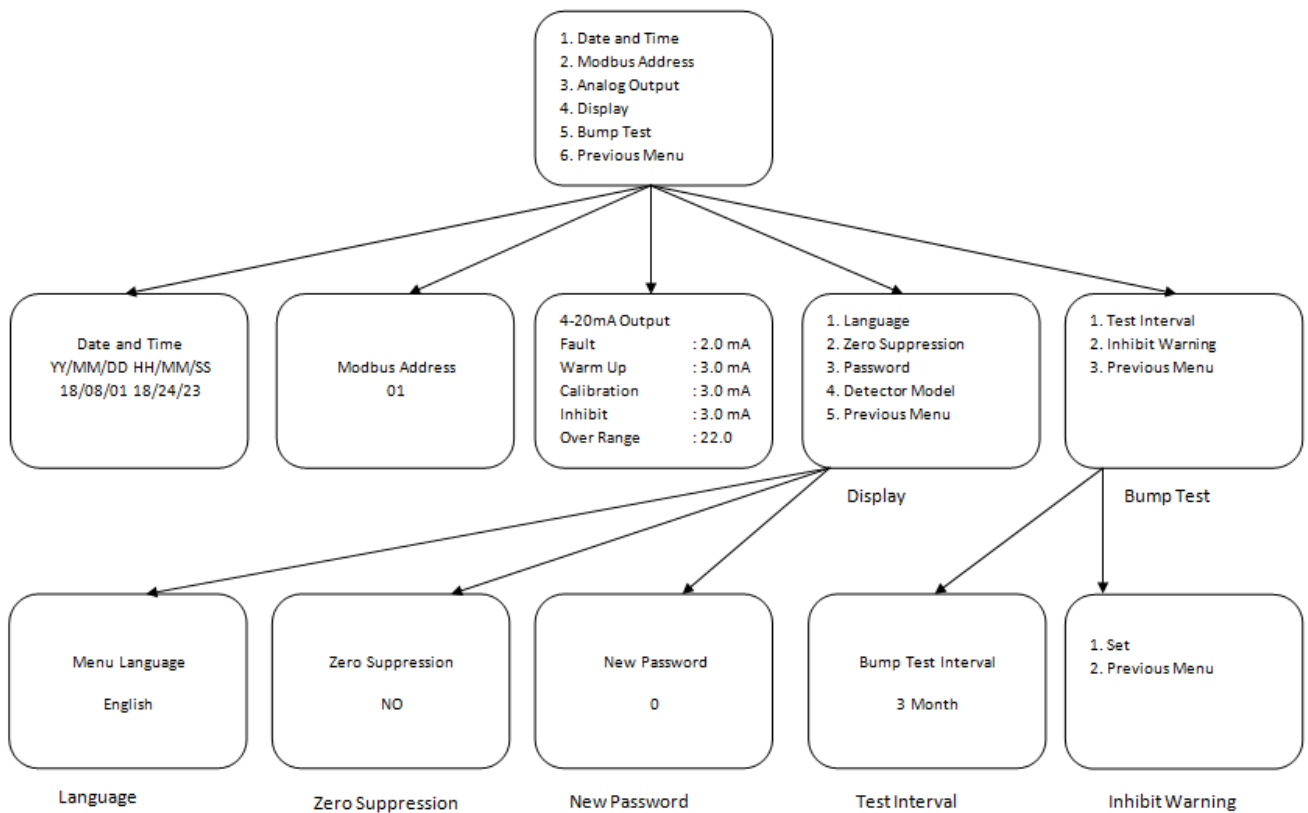

Diagram17: Configure menu structure

Change date and time

To change date and time select first menu item. Display will show date and time details:

Date and Time
YY/MM/DD HH/MM/SS
18/03/27 15/38/27

The first digit on screen will start blinking once entered the menu step. You can increase or decrease the value via using up and down keys. Once desired value has been set press Enter key to confirm and move to the next digit to set. Once all set press Enter key. The display will show “Successful” message and return back to higher level menu.

Change Modbus address

To change detector address, select “Modbus Address” menu option. In RS485 communication detectors are slave devices and control panel is the master device. Each detector must have unique address to work together in same RS485 communication loop. Select “Modbus Address” menu item via using up and down keys and press Enter key. Display will show default detector address which is 1:

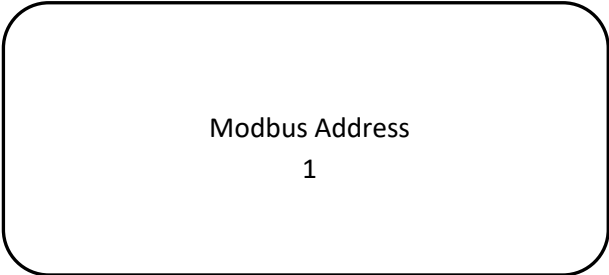

Address can be changed with up and down keys from 1 to 256. Once set to desired address press Enter key long enough. The display will show “Successful” message and return back to higher level menu.

Change Analogue Output

User can adjust analogue output levels depending of the status and function. To do this please select “Analogue Output” menu item on configuration menu via using up and down keys and select Enter key. Screen will display default values used for analogue output:

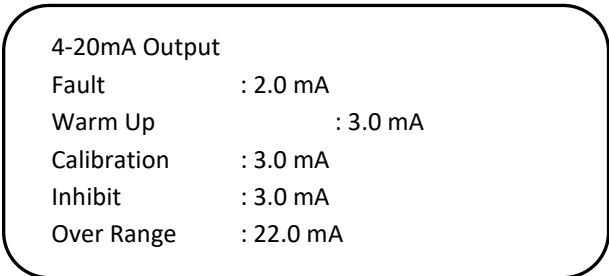

User can adjust these values to desired values depending of the application requirements between 1 to 3.5 mA for Fault, Warm-up, Calibration, Inhibit and 20-22mA for Overrange.

Display Parameters

Detector display can be adjusted as per requirements. The display options are given in Display menu item

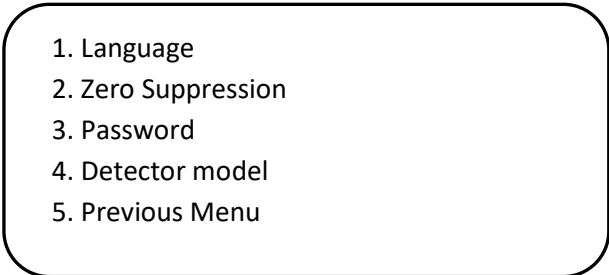

Change Language

The detector display language can be changed to English or Turkish. To change Language first select Configure option on main menu then select Display option and Language option. Once you reach to Language screen you will able to switch display language:

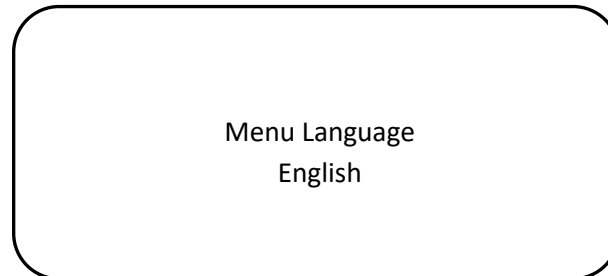

Change Zero Suppression

User can adjust the way showing measurement level around zero level. If zero suppression mode set to NO, detector will display measurement as detected. If zero suppression mode set to YES, detector will show measurement levels as 0 (zero) up to 3% LEL. At 3% LEL it will display measurements as detected.

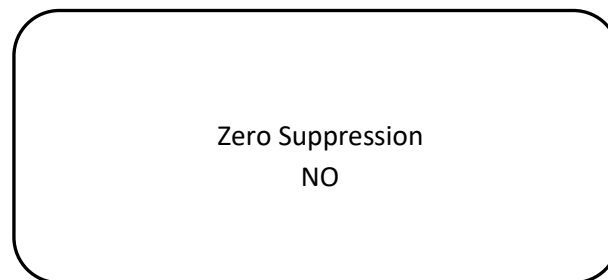

To change zero suppression mode select Zero Suppression option on Display menu and press Enter key. Current zero suppression mode will be displayed. If needed change the value via using up and down keys. Once adjusted press Enter key to record value.

Change password

User must change the default password for security reasons. The default password is 1234. To change password select Password menu item via using up and down keys and press Enter key. Display will ask new password:

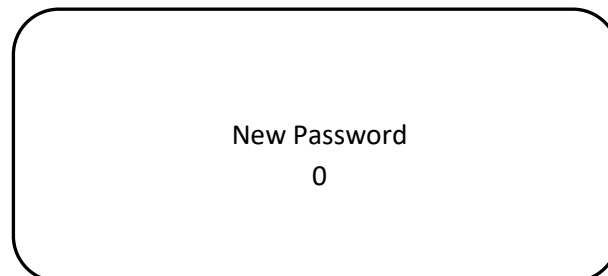

Password must be 4 digits and should be set digit by digit via using up and down keys. When completed, press Enter key long enough to confirm. The display will show "Successful" message and return back to higher level menu. User should remember the password to perform changes later on. If user forgets the password, detector should be returned back to

Prosense to reset password. No Field operation is available to reset password at customer site.

Bump Test

Detectors should be tested to make sure they can perform their operations as defined. To do this bump test should be performed in defined periods. Bump test parameters can be adjusted via using Bump Test options in Configure menu. To start adjustments select Bump Test step on Display menu. A new screen will display with available options:

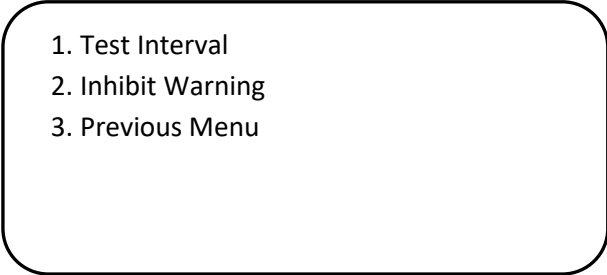

Change Test Interval

To change bump test interval select Test Interval option on Bump Test Menu.

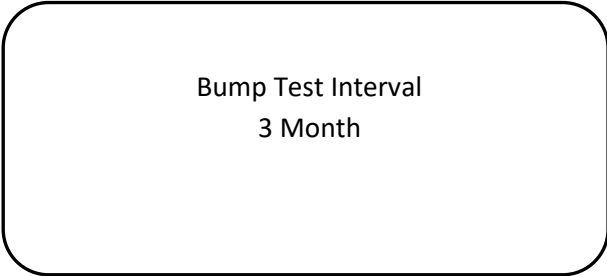

Once the bump test interval menu shown the time value will start blinking. User can change the value via using up and down keys. Select Enter key to save the value when adjustment done. The display will show “Successful” message and return back to previous menu.

Adjust Inhibit warning

User can set or clear inhibit warning via using Inhibit warning option on Bump Test Menu. To adjust warning please select Inhibit warning menu option. A new menu shown including possible adjustment option:

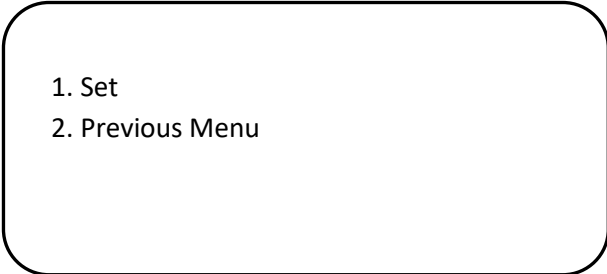

If inhibit warning already set, the screen will display clear option:

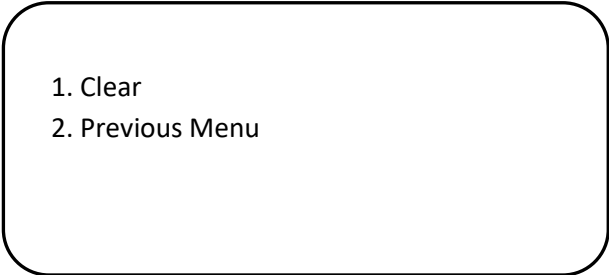

Once decided select the option and press Enter key. The display will show “Successful” message and return back to previous menu.

Information Menu options

Information menu provides more detailed information about measurements, events and device itself. The Information menu structure is given in below diagram:

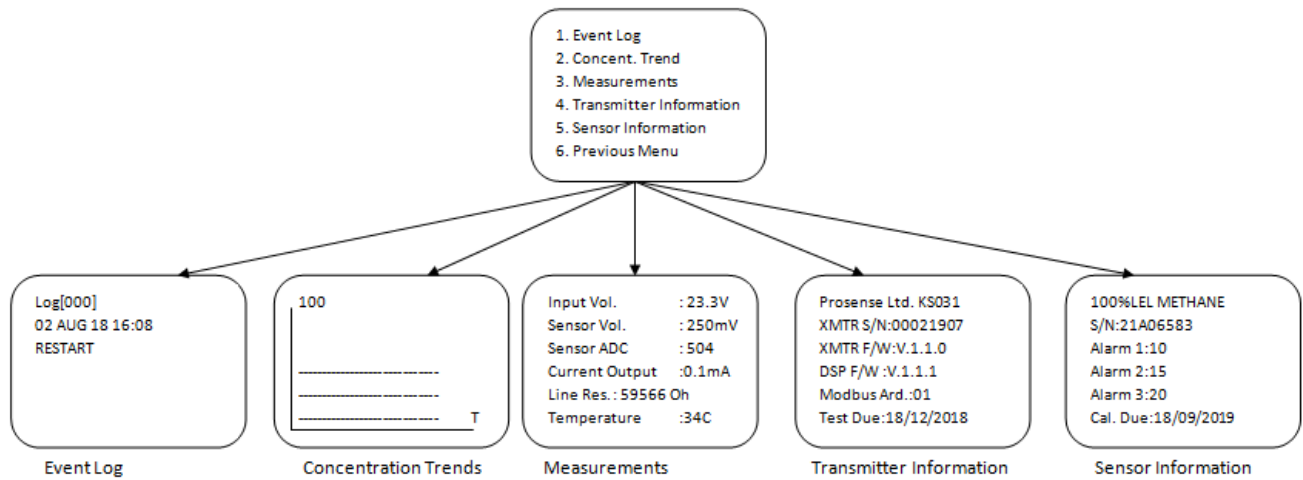
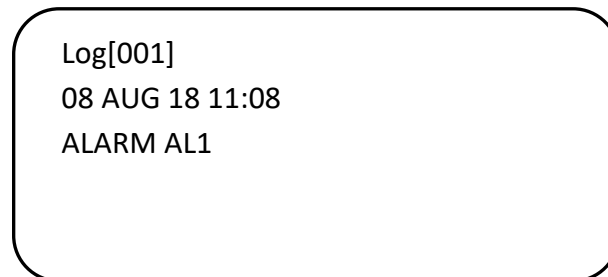

Diagram18: Information menu structure

Display Event Logs

Detector records all events starting from its power-on. To display recorded events, select Event log option in Information menu. Detector will list the events:



The screen can display only one event. To see all events use up and down keys. All events starting from first power-on has been saved in detector memory. It can store up to 250 events.

Display Concentration Trends

PQ detector can show gas concentration trends in screen as it is recording all the measurement data in last 8 hours. Once this option selected a graphic screen will shown to display gas measurements:

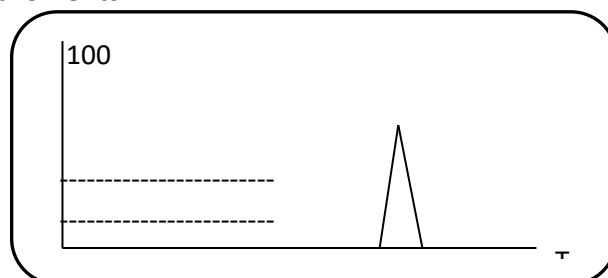

To return back to previous menu please press Enter key till the screen changes.

Display Measurements

To get more details about the measurements please select measurements option in Information menu. Detector will display the voltage, current and temperature levels as in below example:

Input Vol. :23.3V
Sensor Vol. :2506mV
Sensor ADC :504
Current Output :4mA
Line Res. :300 Ohm

Display Transmitter information

To get details about transmitter and firmware level use transmitter information step in Information menu. A screen will display details.

Prosense Ltd. KS031
XMTR S/N:00021907
XMTR F/W:V.1.1.0
DSP F/W :V.1.1.1
Modbus Adr.:01

To return back to previous menu please press Enter key till the screen changes.

Display Transmitter information

To get details about transmitter and firmware level use transmitter information step in Information menu. A screen will display details.

100%LEL METHANE
S/N:21A06583
Alarm 1:10
Alarm 2:15
Alarm 3:20

To return back to previous menu please press Enter key till the screen changes.

Test Menu Options

User can execute tests to check detectors functions. Test menu structure is given in below diagram:

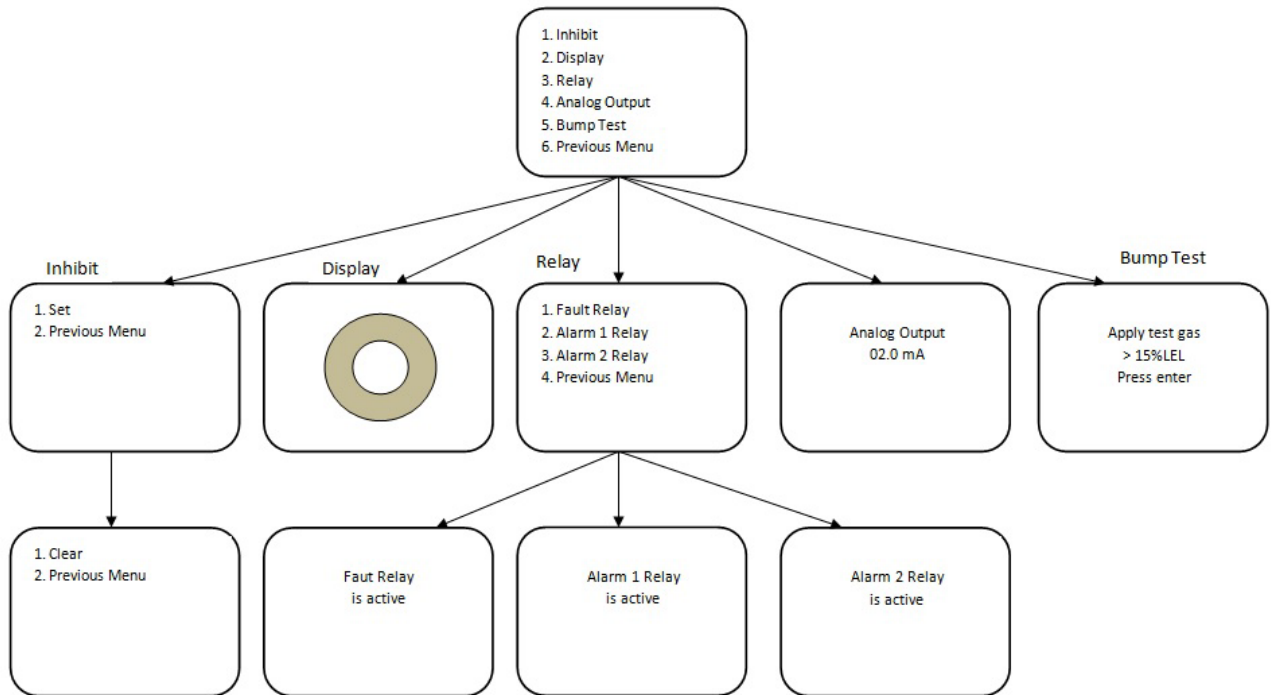
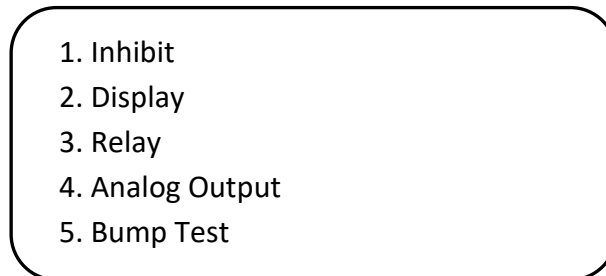

Diagram 19: Test menu structure

To perform tests select Test menu item via up and down keys then press Enter key. The screen will display test options:



To execute tests select desired test option and press Enter key. To return back to previous menu please select Previous Menu option and press Enter key.

Run Inhibit test

User can initiate detector to work in inhibited mode. In this mode detector will provide the signal level defined in configuration details for inhibited mode (default is 3mA) and the alarms will be deactivated. When Inhibit option selected in Test menu below screen will display to set inhibit detector:

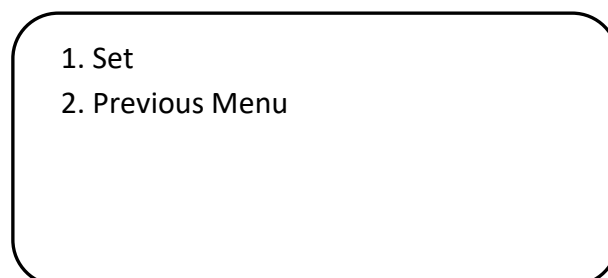

If user finish the work or test it is necessary to clear inhibit mode to return detector to normal operation. To do this user should re-enter to Inhibit menu in Test menu. The clear option will be displayed at this time:

- 1. Clear
- 2. Previous Menu

Run Display test

To execute display tests select Display option on Test menu and press Enter key. The detector program will start display test via drawing different patterns. It might take one minute to complete test. The display will return back to Test menu when test completed.

Run Relay test

It is possible to check relay functions via using menu options. Relays are only available if optional relay module installed on to detector main board. To run relay test please select test menu and select Relay option. Screen will display three options to test as there are three relays on relay module. Select the menu option related to desired relay test and press Enter key.

- 1. Fault Relay
- 2. Alarm 1 Relay
- 3. Alarm 2 Relay
- 4. Previous Menu

If fault relay test selected, detector will activate the relay and screen will display information:

Fault Relay
is active

If alarm relay selected, detector will activate related alarm relay and screen will display information:

Alarm 1 Relay
is active

To return back to previous screen please press Enter key till the screen updated with previous menu items.

Run Analogue Output test

To test analogue output level user can initiate the analogue output test in Test menu. Once Analogue Output option selected press Enter Key. Screen will display the analogue output level. User can increase or decrease the output signal level via using up and down keys.

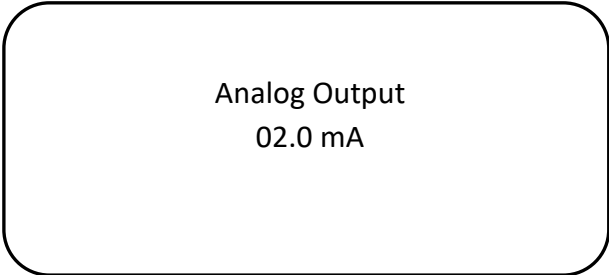

To return back from Analogue Output test please press Enter key till the screen updated with previous menu items.

Run Bump Test

Bump test can be run at any time when needed. The Bump test runs depending of the parameters defined for bump test in configuration details. To initiate bump test please select Bump test menu item in Test menu and press Enter key. Screen will display messages that requesting user to apply test gas and press Enter

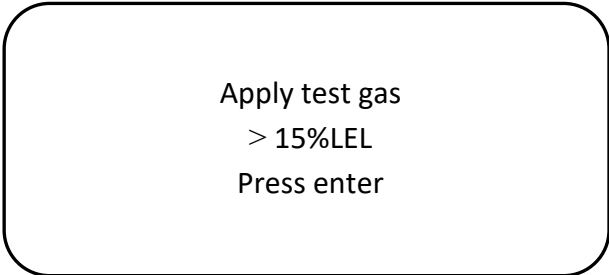

User should provide necessary gas and press Enter. The screen will return back to measurement screen and show the measurement for 30 seconds.

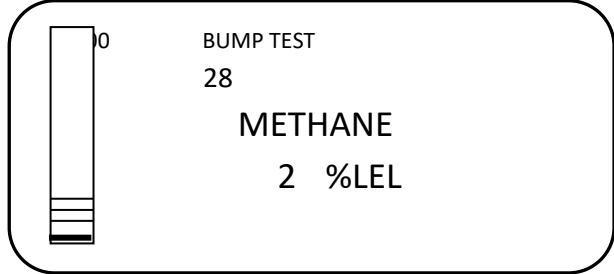

While test executed detector will automatically went in to inhibited mode and Fault LED will start blinking. After 30 seconds screen will alert user to remove the test gas from detector:

Remove applied gas

Detector will return to measurement screen for another 30 seconds with same message

0
BUMP TEST
23
METHANE
0 %LEL

Once the time counted down to zero the screen will display test results:

Start Concentration
0%LEL
Peak Concentration
24%LEL
End Concentration
0%LEL

If test fails the screen will indicate the result

Start Concentration
0%LEL
Peak Concentration
24%LEL
End Concentration
0%LEL

Once test completed screen will display back to Test menu items.

Calibration

It is recommended to periodically carry out calibration to ensure correct operation. Prosense PQ series detector calibration includes two steps as zero and span calibration. It is possible to perform each step independently. Prosense recommends to perform both calibration steps for correct calibration. Detector should be powered and stabilized for at least 4 hours before calibration. During the calibration phases the detector output is inhibited (default 3mA) to avoid false alarms. Zero calibration of infrared sensors should be done with N2 and zero calibration of other sensors should be done with zero air (O2 and N2 gas mixtures). It is possible to use calibration gas from 25%LEL to 75%LEL gas concentrations via adjusting reference gas details on detector menu for calibrating flammable gas detectors. It is necessary to use international traceable gases.

To calibrate the detector, use an appropriate span gas cylinder, constant flow regulator and Prosense Gas Cap. The gas flow rate must be 0,5lt/min for correct calibration.

It is recommended to use a compressed air cylinder (20.9%Vol oxygen) to perform the zero calibration if the area where the detector is located contains any residual amount of the target gas. If no residual gas is present then the background air can be used to perform the zero calibration.

To perform calibration procedure a hand terminal or screen is necessary. Attach hand terminal to detector and press Enter to reach menu. The screen will request password information:

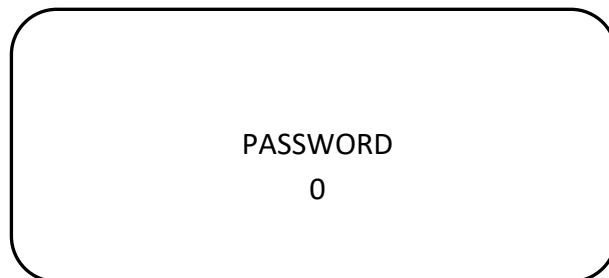

The default password is 1234. Use updated password if default password is changed. You need to set values via using up and down keys. Once the value is set press Enter again to confirm and move to the next digit. The digit confirmed will be made invisible by detector program:



If the password is wrong the display will return to measurement screen. The screen will show menu options when correct password entered:

1. Alarm Settings
2. Calibrate
3. Configure
4. Information
5. Test
6. Exit

Select Calibration. Screen will show calibration options:

1. Set Zero
2. Set Span
3. Cancel Cal
4. Reference Gas
5. Cal. Interval
6. Previous Menu

It would be better to first set reference gas details and calibration cycle period as these values cannot be altered once calibration started for zero or span. Zero or Span calibration can be performed separately at any time. It is recommended to perform Zero calibration first and perform Span calibration following zero calibration completion. Calibration menu structure is given in below diagram:

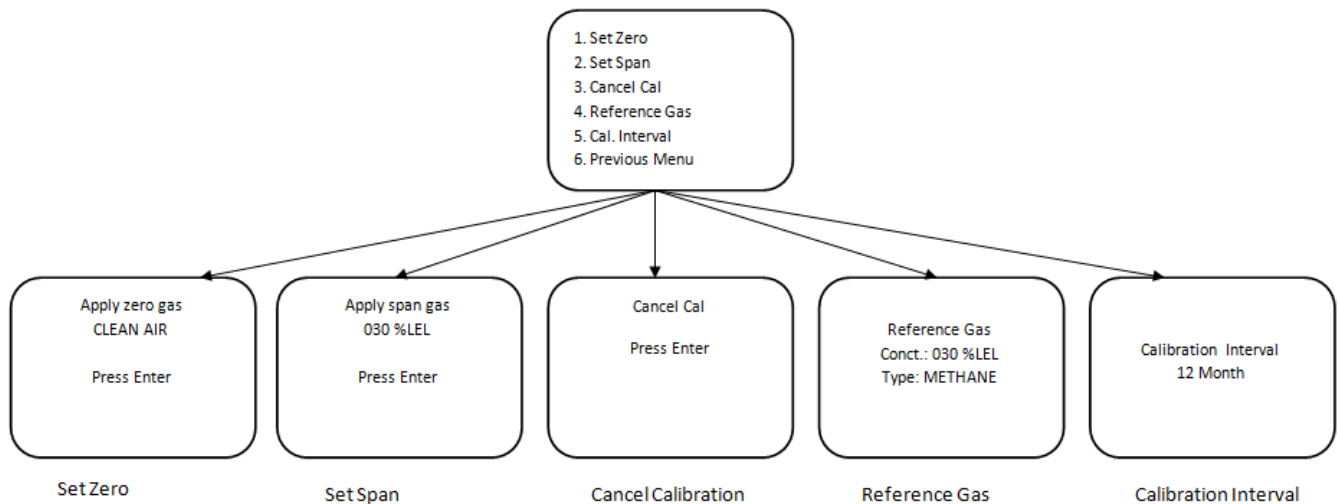
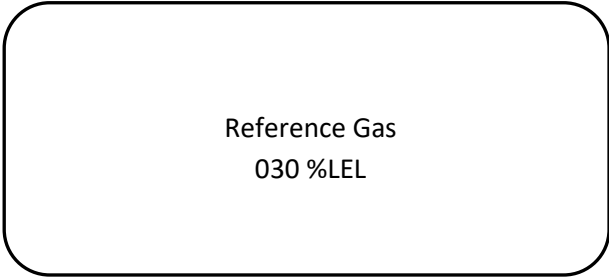

Diagram 20: Calibration menu structure

Set Reference Gas details

During calibration technician should use a certificated specific gas. The details of the gas should be entered before starting the calibration. Otherwise detector program will use default values entered at factory. If the calibration gas is different than default gas specifications the calibration will fail or will be wrong. Select fourth item 'Reference Gas' on calibration menu to

set details of the gas you will use during calibration. The default value is % 30 LEL will be displayed:



The first digit will start blinking on screen. You can change the value of each digit with up and down keys. Once set, confirm value with Enter key and move to the next digit.

Set Calibration Cycle

Prosense recommends performing calibration with six months period. Hence this default value is set to detector in factory. Detector will be faulted when calibration period expire. If user wants to use different calibration period this should be set via using the option "Cal Cycle" on calibration menu. Select "Cal Cycle" and press Enter. A new screen will display to allow you set your calibration period:

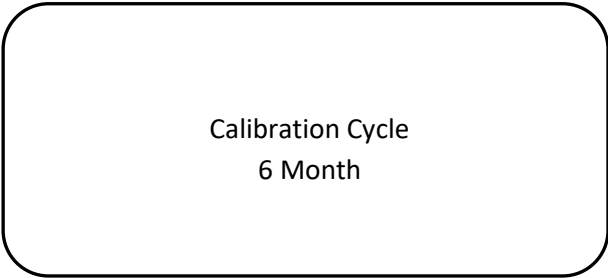

The number will be blinking. Value can be adjusted using up and down keys. Once set press Enter key to confirm and return back to calibration menu.

Zero Calibration

Select Set Zero option on calibration menu and press Enter key to start zero calibration. Program will request a confirmation to start zero calibration:

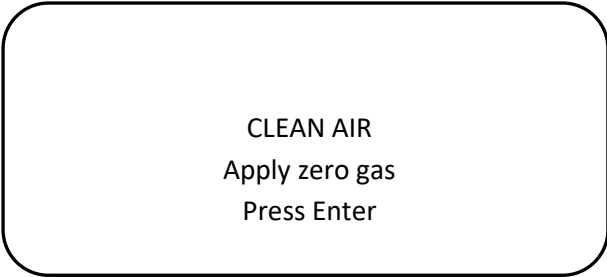

When entered it will start countdown from 60 to 0:

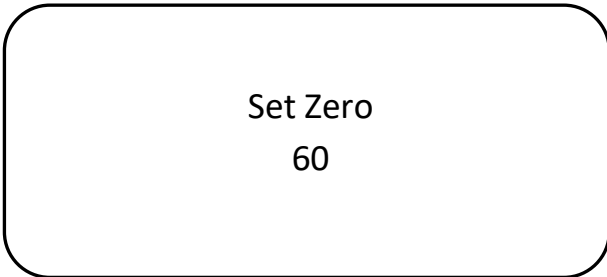

Zero gas should be applied to sensor during 60 seconds. For catalytic, pellistor and electrochemical sensors use clean air gas, for infrared sensors use N2 gas. For more details contact Prosense. Detector will automatically perform zero calibration while gas applied to sensor during this period.

Span Calibration

To perform Span calibration Select Set Span option on calibration menu and press Enter key to start span calibration. At same time prepare the span gas cylinder and regulator; mount the calibration adaptor to the sensor head and apply gas to the detector. Program will request a confirmation to start Span calibration:

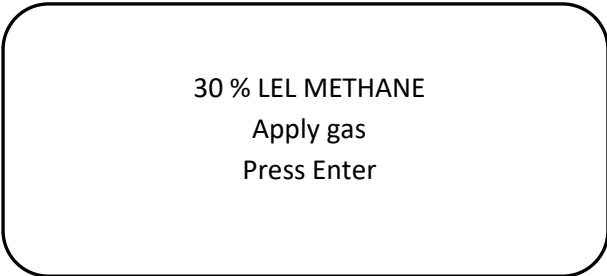

After pressing Enter key screen will again show countdown from 60:

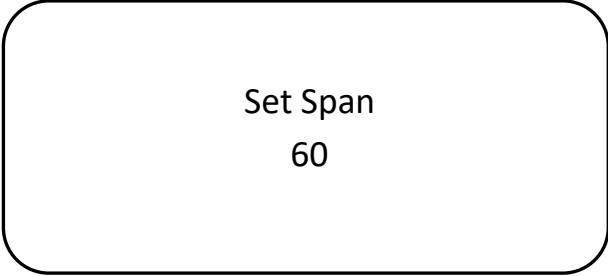

Span gas should be applied to sensor during 60 seconds. Detector will automatically set span level. When countdown completed it will return to monitoring screen via exiting from menu. If you try to enter menu detector will ask password again. The alarms will be activated as gas applied to detector and detector exit from calibration mode.

Cancel Calibration

Calibration can be cancelled anytime during calibration operation. If user thinks something done wrong by mistake, should select "Cancel Cal" option on calibration menu. Detector will ask confirmation to cancel:

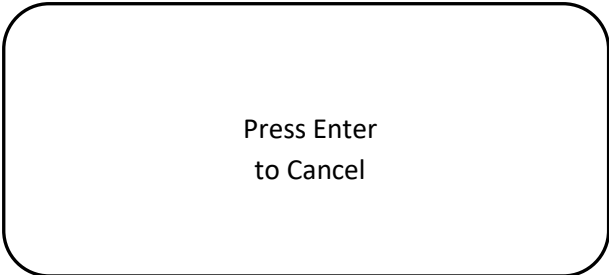

Press Enter key to cancel calibration operation.

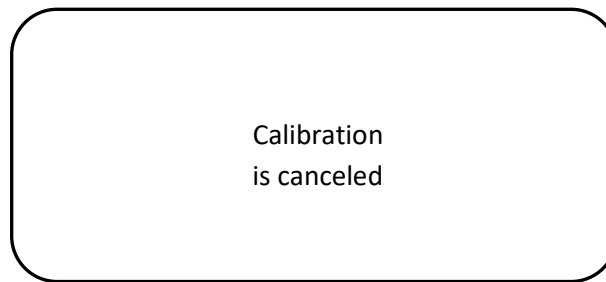

Detector will erase the values recorded during calibration steps and uses previously recorded calibration levels.

Maintenance

CAUTION

The detector contains no user serviceable components. Service or repair should never be attempted by the user. Device repair should be performed only by the manufacturer or trained service personnel.

LIABILITIES

The manufacturer's warranty for this product is void, and all liability for proper function of the detector is irrevocably transferred to the owner or operator in the event that the device is serviced or repaired by personnel not employed or authorized by Prosense, or if the device is used in a manner not conforming to its intended use.

WARNING

For Division applications, do not open cover when explosive gas atmosphere may be present.

Proactive maintenance:

All gas detectors including both for flammable and toxic gases should have to pass a functional test and calibration every three to twelve months according to EN 60079-29-2 industrial standards. The test results and calibration reports should be recorded in maintenance books.

Operational Life:

Typical operational life time is 15 years and it depends on conditions equipment used and below sensing element details.

Catalytic flammable gas sensor made by using the pellistors that suffer from a loss of sensitivity when in the presence of poisons or inhibitors, e.g. silicones, sulphides, chlorine, lead or halogenated hydrocarbons. The pellistors are poison resistant to maximize the operational life of the Catalytic flammable sensor. A typical operating life, subject to the presence of poisons/inhibitors is 48-60 months.

The infrared flammable gas sensor is not affected by the mentioned poisons and has a longer life span around 5 years.

Typical life of a toxic gas sensor which made by electrochemical component is dependent on the application, frequency and amount of gas exposure. Under normal conditions (visual

inspection in 3 months period and test/recalibration in 6 months period), the Prosense Oxygen and other toxic sensors have an expected life equal to or greater than 24 months.

Battery

Detector main board includes a battery (3.3V, 10mA). The purpose is to keep event logs and recorded values to prevent data loss in case of power outage. Battery lifetime is 5 years. Equipment is not a battery operated and battery is not providing power to detector. Detector will alert battery fault in case of any error on battery voltage level.



Do not remove or replace the battery!

Sensor replacement:

The Flammable Catalytic and Toxic ECC cells that are used with the Prosense Sensor Head have limited serviceable parts. Detector must be diagnosed by service personnel when they have reached the end of their operational life or faced with a fault to follow correct procedure.

Pellistor sensor replacement:

Due to current technical design pellistor sensors are not replaceable in the field. The whole sensor head assembly must be replaced once the pellistor sensor has reached end of its life or in case of any failure.

Electrochemical sensor:

The electrochemical sensors are mounted to sensor electronic module inside the sensor head and it is possible to perform replacement in the field. Once replacement sensor on hand follow the steps given below:

- 1- Power-off the detector via disconnecting power cable from control panel or supply
- 2- Use allen key to loosen locking grub screw on sensor head
- 3- Remove the sensor head cap
- 4- Check the sinter and if it blocks the air ventilation replace the sinter via steps given in "Sinter Replacement" section.
- 5- Remove electrochemical sensor from sensor module.
- 6- Check sensor electronic module. Some EEC sensors might leak to the sensor PCB and create unrepairable hazard on PCB. The whole sensor head must be replaced if there is any chemical leakage on sensor PCB.
- 7- Install the new sensor in to sensor PCB.
- 8- Install the sensor head cab and fix the locking grub screw.
- 9- Power-on the detector and wait at least 4 hours
- 10- Perform full calibration.

Infrared Sensor:

The NDIR sensors are mounted to sensor electronic module (sensor PCB) inside the sensor head and it is possible to perform replacement in the field. Once replacement sensor on hand follow the steps given below:

- 1- Power-off the detector via disconnecting power cable from control panel or supply
- 2- Use allen key to loosen locking grub screw on sensor head
- 3- Remove the sensor head cap
- 4- Check the sinter and if it blocks the air ventilation replace the sinter via steps given in “Sinter Replacement” section.
- 5- Remove NDIR sensor from sensor module.
- 6- Install the new sensor into sensor PCB.
- 7- Install the sensor head cap and fix the locking grub screw.
- 8- Power-on the detector and wait at least 30 minutes
- 9- Perform full calibration.

Sensor PCB replacement:

Due to current technical design restrictions sensors PCBs are not replaceable in the field. The whole sensor head assembly must be replaced once the sensor PCB damaged or in case of any failure.

Sinter replacement:

Due to environmental conditions the metal filter - sinter at sensor head might lost permeability that could negative impact on sensor performance. For example if the installation includes cement or similar dust the sinter would be block the air/gas entry to sensor. The sinter should be checked visually and replaced if necessary. The sinter is located inside the sensor head cap and sensor head cap must be replaced when sinter needs replacement. To replace sinter please check diagram-2 and follow the below procedure:

- 1- Power off the detector via disconnecting power cable from control panel or supply
- 2- Loosen the locking grub screw via allen key
- 3- Unscrew the sensor head cap that holds the dirty sinter
- 4- Remove the sinter holder via using two holes on it
- 5- Remove the old sinter
- 6- Install new sinter to its location, make sure sinter located correctly to designed area
- 7- Install sinter holder and fix completely to hold sinter to go back
- 8- Screw the sensor head cap including the clean sinter
- 9- Fix the Locking grub screw

Sensor head replacement:

Prosense sensor head is a separate part that can be replaced. The sensor head includes integrated sensor, electronic device and sinter in it. PQ series sensor head is pre-calibrated and will start function immediately following the replacement. To replace sensor head:

- 1- Power-Off the detector via disconnecting power cable from control panel or supply
- 2- Open the detector cover
- 3- Disconnect sensor cables from the detector main board
- 4- Remove the sensor head from the body via using Nr 38 wrench key.
- 5- Install sensor head
- 6- Sensor head must be fixed to enclosure with 20Nm torque
- 7- Connect the sensor cables to detector main board
- 8- Close the detector cover
- 9- Power-On Prosense detector
- 10- Leave detector working at least 4 hours in clean air environment
- 11- Check detector calibration.

Detector Transmitter board replacement:

Prosense detector transmitter is the main logic board including all definitions and configuration. Hence it is necessary to perform reconfiguration in case of replacement. Hence the spare part must be ordered by giving the serial number of the detector. The replacement should be done via following steps:

- 1- Power-Off the detector via disconnecting power cable from control panel or supply
- 2- Open the detector cover
- 3- Remove display module from the mounting rails (PQN does not have display module)
- 4- Disconnect sensor, display, power and other external interface cables from the detector main board (see diagram-11)
- 5- Remove the screws mounting the board to enclosure.
- 6- Remove the board
- 7- Install new board and fix via putting screws
- 8- Install sensor and display cables
- 9- Install power and other external interface cables
- 10- Power-on detector and check the LEDs according to steps given in “Commissioning” section
- 11- Leave detector working at least 4 hours in clean air environment
- 12- Check detector calibration.

PQD Detector Display Module replacement:

Prosense PQD display board is a replaceable part. The replacement should be done via following steps:

- 1- Power-Off the detector via disconnecting power cable from control panel or supply
- 2- Open the detector cover
- 3- Remove display module from the mounting rails
- 4- Disconnect display cable from main board (see diagram-11). The display board fixed to the display board and should be disconnected from the socket on main board to remove display module.
- 5- Connect new display boards connector to main board.
- 6- Install display board to mounting rails
- 7- Power-on detector and check the LEDs according to steps given in “Commissioning” section
- 8- Check detector settings and adjust if necessary.

Detector Relay Module replacement:

Prosense PQD relay module is a replaceable part. The replacement should be done via following steps:

- 1- Power-Off the detector via disconnecting power cable from control panel or supply
- 2- Open the detector cover
- 3- Remove display module from the mounting rails (PQN does not have display module)
- 4- Disconnect relay module output connections.
- 5- Remove display module mounting rails that are fixed on top of relay module mounting rails. If there is no display relay module is fixed with screws, remove the screws.
- 6- Remove relay module.
- 7- Install relay module while taking care to connectors directly on main board socket. The main board battery must be relaxed on the empty location of relay module.
- 8- If there is no display module (PQN) fix the relay module via using screws.
- 9- Fix the display module mounting rails on top of relay module mounting rails. These should fix the relay module as well.
- 10- Perform any adjustment necessary about alarm levels and relay operating modes via using jumper on relay module.
- 11- Reconnect relay module output connections.
- 12- Install display module from the mounting rails (PQN does not have display module)
- 13- Power-on detector and check the LEDs according to steps given in “Commissioning” section
- 14- Check detector settings and adjust if necessary.

Safety Manual for PQD-S / PQN-S

Prosense PQD-S and PQN-S gas detectors have functional safety features defined by IEC and EN standards. The following documents, in whole or in part, are normatively referenced in this document and are indispensable for its application. For dated references, only the edition cited applies. For undated references, the latest edition of the referenced document (including any amendments) applies.

- IEC EN 60079-0, Explosive atmospheres – Part 0: Equipment – General requirements
- IEC EN 60079-29-1: Gas detectors - Performance requirements of detectors for flammable gases
- IEC EN 50270: Electromagnetic compatibility. Electrical apparatus for the detection and measurement of combustible gases, toxic gases or oxygen
- IEC EN 50271: Electrical apparatus for the detection and measurement of combustible gases, toxic gases or oxygen. Requirements and tests for apparatus using software and/or digital technologies
- IEC EN 50402: Electrical apparatus for the detection and measurement of combustible or toxic gases or vapours or of oxygen. Requirements on the functional safety of gas detection systems
- IEC 61508-1 Functional safety of electrical/electronic/programmable electronic safety-related systems - Part 1: General requirements
- IEC 61508-2 Functional safety of electrical/electronic/programmable electronic safety-related systems - Part 2: Requirements for electrical/electronic/programmable electronic safety-related systems
- IEC 61508-3 Functional safety of electrical/electronic/programmable electronic safety-related systems - Part 3: Software requirements
- IEC 61508-4 Functional safety of electrical/electronic/programmable electronic safety-related systems - Part 4: Definitions and abbreviations
- IEC 61508-5 Functional safety of electrical/electronic/programmable electronic safety related systems - Part 5: Examples of methods for the determination of safety integrity levels
- IEC 61508-6 Functional safety of electrical/electronic/programmable electronic safety-related systems - Part 6: Guidelines on the application of IEC 61508-2 and IEC 61508-3
- IEC 61508-7 Functional safety of electrical/electronic/programmable electronic safety-related systems - Part 7: Overview of techniques and measures

Safety Concept

Functional Safety concept is based on measurement process. If the equipment cannot perform its main function due to any problem or failure it should switch to the safe state which is raising failure message to the connected devices and/or systems.

Definition of safe state:

- Perform measurement
- Fail, if cannot perform measurement

- Alert, if measurement range is not suitable

Equipment provides safety outputs for below output types:

- Analogue current output
- Switching relay output

The safety function of equipment covers Pellistor (Catalytic) sensor and related electronic board (PRS-K033).

Safety Function:

The element safety function of the PQD-S and PQN-S model gas detector is defined as follows:

1. Measure the concentration of gas and indicate the measurement by means of a 4-20mA signal.

If relays are fitted then the following additional safety functions shall be performed:

2. Indicate if the measured concentration of gas is greater than alarm 1 on-threshold by energising the first normally energised alarm relay, with the relay response following the calculated gas level with a delay of no more than 1 second.
3. Indicate if the measured concentration of gas is greater than alarm 2 on-threshold by energising the second normally energised alarm relay, with the relay response following the calculated gas level with a delay of no more than 1 second.

PQD-S and PQN-S detectors provides SIL2 level functional safety figures with hardware fault tolerance 0 (1oo1) and can achieve SIL 3 level capability in redundant system implementation (1oo2) according to IEC EN 61508.

Safety State

Equipment provides safety outputs through:

- Analogue current output
- Switching relay output

Analogue Output Safety State:

Analogue output of equipment provides state information to external devices via current level. The output provides signal between 0- 22mA:

- Equipment provides meaningful measurement level between 4-20mA current level. The external safety device must evaluate 4-20mA current level as measurement level information. The evaluation of measurement level regarding a dangerous gas concentration must be performed by an external safety device.
- Equipment provides 0-2mA current level as safety state indication when it detects any internal error. The external safety device must evaluate 0-2mA current level as fault condition.

- Equipment provides 20-22mA current level as overrange state indication. The external safety device must evaluate 20-22mA current level as overrange condition which is a dangerous gas concentration.

State details and indications are given in below tables:

PQD-S Analogue output states and indications

Signal	Meaning	Output(mA)	LED green	LED yellow	LED red	Display
Power-off	Device is off, not performing measurement	0	off	off	off	Power-off
Warm-up	Device is working and waiting for sensor stabilization after power-on. Actual measurement level is not used to provide measurement result or alarm generation.	3	on	on	off	Warm-up
Fault	Device is in fault condition, not performing measurement	<2	on	on	off	Fault
Fault	Analogue output circuit is faulty and output must be blocked	0	on	on	off	Fault
Calibration	Device is working and performing calibration for sensor. Actual measurement level is not used to provide measurement result or alarm generation.	3	on	on	off	Calibration
Normal	Device is performing measurement	4-20	on	off	off	Measured level
Alarm	Measured gas level is higher than defined alarm level	4-20	on	off	on	Alarm
Ovrange	Measured gas level is higher than measurement range	20-22	on	on	on	Ovrange
Underrange	Measured gas level is deviated tha minimum allowed level	<2	on	on	off	Fault

Table 15: PQD-S Analogue output states and indications

PQN-S Analogue output states and indications

State	Meaning	Output(mA)	LED red
Power-off	Device is off, not performing measurement	0	off
Warm-up	Device is working and waiting for sensor stabilization after power-on. Actual measurement level is not used to provide measurement result or alarm generation.	3	blinking 2Hz
Fault	Device is in fault condition, not performing measurement	<2	blinking 2Hz
Fault	Analogue output circuit is faulty and output must be blocked	0	blinking 2Hz
Calibration	Device is working and performing calibration for sensor. Actual measurement level is not used to provide measurement result or alarm generation.	3	blinking 2Hz
Normal	Device is performing measurement	4-20	blinking 1Hz
Alarm	Measured gas level is higher than defined alarm level	4-20	blinking 1Hz
Overrange	Measured gas level is higher than measurement range	20-22	blinking 1Hz
Underrange	Measured gas level is deviated the minimum allowed level	<2	blinking 1Hz

Table 16: PQN-S Analogue output states and indications

Switching Output Safety State

The safe state is when fault relay switched in off position, only when the fault relay coil is energized (contact closed) are the output states valid. The evaluation of the fault relay must be performed by an external safety device.

Alarm Relay-1

Indicate if the measured concentration of gas is greater than alarm 1 on-threshold by energising the first normally energised alarm relay, with the relay response following the calculated gas level with a delay of no more than 5 second.

Alarm Relay-2

Indicate if the measured concentration of gas is greater than alarm 2 on-threshold by energising the second normally energised alarm relay, with the relay response following the calculated gas level with a delay of no more than 5 second.

Fault relay output

Fault relay should be designed as closed circuit / de-energise to trip principle and provide device state information. As it is a switching output it has two states and behaves as given in below table:

Status	Output(mA)	Fault Relay		Alarm 1 Relay		Alarm 2 Relay	
		Energy (Coil)	Circuit (Out)	Energy (Coil)	Circuit (Out)	Energy (Coil)	Circuit (Out)
Power-off	0	De-energized	Contact open	De-energized	Contact open	De-energized	Contact open
Warm-up	3	De-energized	Contact open	De-energized	Contact open	De-energized	Contact open
Fault	2	De-energized	Contact open	De-energized	Contact open	De-energized	Contact open
Calibration	3	De-energized	Contact open	De-energized	Contact open	De-energized	Contact open
Zero gas	4	Energized	Contact close	De-energized	Contact open	De-energized	Contact open
Alarm-1 level	Adjustable	Energized	Contact close	Energized	Contact close	De-energized	Contact open
Alarm-2 level	Adjustable	Energized	Contact close	Energized	Contact close	Energized	Contact close
Full Scale Gas	20	Energized	Contact close	Energized	Contact close	Energized	Contact close
Over-range	22	Energized	Contact close	Energized	Contact close	Energized	Contact close
Under-range	2	De-energized	Contact open	De-energized	Contact open	De-energized	Contact open

Table 17: PQD-S and PQN-S Switching output states and indications

Other than given states the detector is working fine and fault relay will be energised and relay contact will be open circuit.

SIL Capability

The device is suitable for use in a safety instrumented system up to SIL 2 with a hardware fault tolerance HFT=0 (1oo1) and up to SIL 3 with a hardware redundant system implementation (1oo2) according to IEC EN 61508.

The gas detector performs 118 diagnostics totally in different time intervals. The longest diagnostic test interval is 20 minute, but when an internal failure (error) is detected, it will be recognised within 10 seconds.

The Prosense PQD-S/PQN-S series gas detector with Pellister sensor board (Type no.PRS-K033) safety parameters listed below were provided by TÜV Rheinland in report XXYYZZ:

Safety related parameters Variants	A	B	C
Sensor board Pellistor	PRS-K033 Rev. 1.0		
Safety architecture	1oo1 / 1oo2		
Mode of operation	Low Demand mode		
Safety Integrity Level (SIL)	SIL2 with HFT = 0 SIL3 with HFT = 1		
Systematic Capability (SC)	SC3 (with HFT 1)		
Device type	Type B		
Proof test interval in years	1 a		
Safety related parameters Variants	A	B	C
Undetected dangerous failure rate λ_{DU}	68 fit	166 fit	167 fit
Detected dangerous failure rate λ_{DD}	1401 fit	1488 fit	1594 fit
Dangerous failure rate $\lambda_D (\lambda_{DD} + \lambda_{DU})$	1469 fit	1654 fit	1761 fit
Safe failure rate λ_S	1469 fit	2274 fit	2381 fit
Safe Failure Fraction (SFF)	> 90%	> 90%	> 90%
1oo1 architecture configuration			
Hardware Fault Tolerance (HFT)	0		
Mean time to recovery (MTTR)	0h		
Mean Repair Time (MRT)	0h		
Average Probability of dangerous Failure	3,85 E-04	9,71 E-04	9,74 E-04
PFD (%) of SIL 2	3,9%	9,7%	9,7%
1oo2 architecture configuration			
Hardware Fault Tolerance (HFT)	1		
Mean time to recovery (MTTR)	24h		
Mean Repair Time (MRT)	24h		
Common Cause Factor β	5%		
Common Cause Factor β_D	5%		
Average Probability of dangerous Failure	1,94 E-05	4,96 E-05	4,98 E-05
PFD (%) of SIL 3	1,9%	5,0%	5,0%

Table 18: PQD-S and PQN-S Safety parameters

Variante A: Using only the 4- 20 mA output for Alarming

Variante B: Using only the Alarm- relays for Alarming

Variante C: Using the Alarm-relays together with 4-20 mA output for Alarming

SFF: Safe Failure Fraction. A percentage of safe failures as compared to all failures

PFDavg: Average probability of failure to perform its design function on demand

Proof Test Interval

The purpose of a proof test is to return the unit to “as new” in terms of its safety parameters. The proof test interval is 1 year. According to IEC 61508, users are allowed to extend the proof test interval to meet their system needs. Prosense allows such an extension, as long as the user follows the proper calculation method for calculating a proof test interval as defined in IEC 61508 for the desired SIL level. This proof test interval will vary depending on system, hardware architecture and application.

Note: The proof test interval should not preclude more frequent maintenance of Prosense equipment in accordance with the Operating Instructions if site conditions require it.

Proof test procedure

Caution: Gas readings may be generated during this procedure.

A. Inspect PQD-S / PQN-S

Detector should be inspected and cleaned.

- Inspect the equipment, its junction box and cabling for any signs of physical damage.
- Inspect the Sensor Head and clean if required. If still stick dust or chemical exist remove the Sensor Head cover and inspect the sinter.
- Clean any dust or contaminants from the sinter using a soft cloth or cotton bud. Do not use solvents or abrasive cleaners. If sinter is still dirty or having sing of contaminats replace it.

B. Re-Calibrate PQD-S / PQN-S

- Select **Calibrate ->Set Zero** option on calibration menu and press Enter key to start zero calibration. Program will request a confirmation to start **Zero** calibration.
- Apply necessary gas for zero. For more details check user manual. Detector will automatically perform zero calibration while gas applied to sensor during 60 seconds period.
- Select **Calibrate ->Set Span** option on calibration menu and press Enter key to start zero calibration. Program will request a confirmation to start **Span** calibration.
- Apply necessary gas for Span. For more details check user manual. Detector will automatically perform Span calibration while gas applied to sensor during 60 seconds period.

C. Execute PQD-S / PQN-S Tests

Detector should be functionally checked using an appropriate test gas.

Caution: Gas readings will be generated during this procedure.

Go to Test menu and Inhibit the 4-20mA output at first to prevent false alarms. Then follow the tests via using menu options. For more details please check user manual including all steps for related tests are explained in detail. Below tests should be executed:

D. Run PQD-S Display test

Run display test and check OLED display and LED status for correct operation. All LEDs must be operational during the test.

E. Run Relay test

The switching outputs can be set to activate to prove correct operation of the output.

- Perform Relay output test for Fault relay
- Perform Relay output test for Alarm-1 relay
- Perform Relay output test for Alarm-2 relay

F. Run Analogue Output test

The 4-20 mA output can be set to a fixed value, to prove correct operation of the 4-20 mA loop. *The 4-20 mA output can be monitored either at the control room or locally with a multimeter.*

- Perform analogue output test for 2 mA
- Perform analogue output test for 3 mA
- Perform analogue output test for 4 mA
- Perform analogue output test for 12 mA
- Perform analogue output test for 20 mA

G. Run Bump Test

Detector should be functionally checked using an appropriate test gas.

Caution: Gas readings will be generated during this procedure.

Follow the instruction in user manual for Bump test. The default bump test period is 3 months. This period must be adjusted according to site requirements.

Special Notes

1. The HART® Communications and the RS485 MODBUS communication options must not be used for safety purposes.
2. Prosense PQD-S/PQN-S must be protected from over voltage conditions (i.e. above the supply voltage specification).
3. PQD-S and PQN-S models must be operated and maintained as defined in sections:
 - PQ Series Detector Configuration
 - System Status
 - Commissioning
 - Detector Settings
 - Calibration
 - Maintenance

Fault Status Codes:

Fault Message	Fault Description
SENSOR	Sensor is in fault condition
ADC	ADC circuit is not functioning correctly
CURRENT	Detector is not generating analogue output signal
POWER	Power input is out of range
CPU RAM	RAM fault detected
CPU FLASH	Flash error detected
EEPROM	EEPROM error detected
CAL DUE	Defined calibration period is passed, calibration needed
BATTERY	Battery is in fault condition
RS485	RS485 communication failure
RELAY CARD	Relay module communication error
CPU	CPU failure
CPU STACK	Stack Overflow Error
TEST DUE	Defined test period is passed, test execution needed
LINE	Analogue output is not connected or shortcircuited
NO COMM	Display communication failure

Table 19: PQ Series Fault Status Codes

Spare Parts

Product Code	Description
PY-05S-05	Pellistor Sensor Head, 0-100 %LEL
PY-05S-03	Infrared Sensor Head, 0-100 %LEL
PY-05S-36	Hydrogen Sensor Head, 0-500 ppm
PY-05S-36B	Hydrogen Sensor Head, 0-1000 ppm
PY-05S-36C	Hydrogen Sensor Head, 0-2000 ppm
PY-05S-44	Carbon monoxide Sensor Head, 0-300 ppm
PY-05S-44B	Carbon monoxide Sensor Head, 0-500 ppm
PY-05S-44C	Carbon monoxide Sensor Head, 0-1000 ppm
PY-05S-48	Ammonia Sensor Head, 0-100 ppm
PY-05S-48B	Ammonia Sensor Head, 0-1000 ppm
PY-05S-60	Acetylene Sensor Head, 0-100 %LEL
PY-05S-62	Ethylene Oxide(ETO) Sensor Head, 0-20 ppm
PY-05S-62B	Ethylene Oxide(ETO) Sensor Head, 0-100 ppm, 1 Year
PY-05S-64	Hydrogen Sulfide(H ₂ S) Sensor Head, 0-100 ppm
PY-05S-64B	Hydrogen Sulfide(H ₂ S) Sensor Head, 0-500 ppm
PY-05S-65	Oxygen Sensor Head, 0-25% vol
PY-05S-66	Sulfide Dioxide Sensor Head, 0-10 ppm
PY-05S-67	Nitric Oxide Sensor Head, 0-250 ppm
PY-05S-68	Nitrogen Dioxide Sensor Head, 0-30 ppm
PY-05S-69	Chlorine Sensor Head, 0-10 ppm
PY-05S-71	Carbondioxide Sensor Head, 0-5000 ppm
PY-05S-71B	Carbondioxide Sensor Head, 0-5% Vol
PY-05S-72	Freon Sensor Head, 0-2000 ppm
PY-05S-74	Formaldehyde Sensor Head, 0-10 ppm
PY-05K-N	PQN Enclosure
PY-05K-D	PQD Enclosure
UPY-05T	PQ Transmitter
UPY-05T-D	PQD OLED Display Assembly
UPY-05S-03	PQ Series Infrared Sensor, 0-100 %LEL
UPY-05S-05	PQ Series Pellistor Sensor, 0-100 %LEL
UPY-05S-44	PQ Series Carbon Monoxide Sensor, 0-300 ppm
UPY-05S-44B	PQ Series Carbon Monoxide Sensor, 0-500 ppm
UPY-05S-44C	PQ Series Carbon Monoxide Sensor, 0-1000 ppm
UPY-05S-48	PQ Series Ammonia Sensor, 0-100 ppm

Product Code	Description
UPY-05S-48B	PQ Series Ammonia Sensor, 0-1000 ppm
UPY-05S-60	PQ Series Acetylene Pellistor Sensor, 0-100 %LEL
UPY-05S-62	PQ Series Eto Sensor, 0-20 ppm
UPY-05S-62B	PQ Series Eto Sensor, 0-100 ppm
UPY-05S-64	PQ Series Hydrogen Sulfide Sensor, 0-100 ppm
UPY-05S-64B	PQ Series Hydrogen Sulfide Sensor, 0-500 ppm
UPY-05S-65	PQ Series Oxygene Sensor, 0-25% Vol
UPY-05S-66	PQ Series Sulfur Dioxide Sensor, 0-10 ppm
UPY-05S-67	PQ Series Nitric Oxide Sensor , 0-250 ppm
UPY-05S-68	PQ Series Nitrogen Dioxide Sensor, 0-30 ppm
UPY-05S-69	PQ Series Chlorine Sensor, 0-10 ppm
UPY-05S-71	PQ Series Carbon Dioxide Sensor, 0-5000 ppm
UPY-05S-71B	PQ Series Carbon Dioxide Sensor, 0-5% Vol
UPY-05S-72	PQ Series Refrigerant (Freon) Sensor, 0-2000 ppm
UPY-05S-74	PQ Series Formaldehyde Sensor, 0-10 ppm
UPY-05S-75	PQ Series Hydrogen Cyanide Sensor, 0-25 ppm
UPY-05S-76	PQ Series Hydrogen Peroxide Sensor, 0-300 ppm
UPY-05S-80	PQ Series VOC (PID) Sensor, 0-100 ppm
UPY-05S-80B	PQ Series VOC (PID Sensor, 0-1000 ppm
UPY-SH30	SH30 Sensor Head
UPY-SIN	Sinter for SH30

Table 20: PQ Series Spare Part Codes

General specification

Electrical Specifications:

Detector must be powered by a SELV power supply.

PQD/PQN Input	12 to 28VDC (24VDC nominal)
PQD-S / PQN-S	14 to 28VDC (24VDC nominal)
Max Power	Max 4 Watts. at 24VDC
Current output	1-22mA
Fault	1.0 - 3.5 mA (adjustable)
Warm-Up	1.0 - 3.5 mA (adjustable)
Inhibit	1.0 - 3.5 mA (adjustable)
Calibration mode	1.0 - 3.5 mA (adjustable)
Normal gas measurement	4.0 mA to 20.0 mA
Over range	20.0 - 22.0 mA (adjustable)
Under range	Fault signal (1.0 - 3.5 mA - adjustable)
Terminals	3 x screw terminals suitable for wire diameter 0.5 mm ² to 2.5 mm ² (20AWG to 13AWG). Use Copper Conductors Only! 2 x screw terminals suitable for wire diameter 0.5 mm ² to 2.5 mm ² (20AWG to 13AWG) for RS485 digital output. Use Copper Conductors Only!
Relays	3 x (1.25A 30VDC). Selectable normally open or normally closed (switch) and
Communication	RS485, Modbus RTU

Table 21: Electrical specifications

Detector Body Specifications:

Material	Epoxy painted aluminium alloy junction box, 316 - Stainless Steel Sensor Head SS 316 - Stainless Steel Enclosure and Sensor Head
Weight	Aluminium Alloy : 2.1kg - PQD (with Sensor Head) Aluminium Alloy : 1.85kg - PQN (with Sensor Head) Stainless Steel: 4kg - PQD (with Sensor Head) Stainless Steel: 3.85kg - PQN (with Sensor Head)
Mounting	Wall mounting
Entries	3 x ½ NPT field cable entries, ¼ NPT sensor entry *

* Entry specifications may vary depending of the body type, please check Table-1

Table 22: Detector body specifications

Environmental:

IP Rating	IP65 in accordance with EN60529:1992
Operating Temperature	-40°C to +70°C / -40°F to +158°F – For explosion protection -20°C to +60°C / -04°F to +140°F – For performance and Functional Safety
Operating Humidity	Continuous 20-90%RH (non condensing)
Operating Pressure	80-120kPa
Storage Conditions	-30°C to +70°C (-22°F to +158°F) Detectors must be re-calibrated if not installed more than 3 months
Operating Altitude	0-2500m
Use	Indoor and Outdoor

Table 23: Environmental specifications

Default Configuration:

Function	Value/Setting	Meaning
Sensor Type	Automatic detection	PQ automatically detect the sensor
Signal output	2mA (1.0 - 3.5 mA adjustable)	Fault
	3mA (1.0 - 3.5 mA adjustable)	Warm-Up
	3mA (1.0 – 4.0 mA adjustable)	Inhibit
	3mA (1.0 – 4.0 mA adjustable)	Calibration mode
	4.0 mA to 20.0 mA	Normal gas measurement
	22mA (20.0 - 22.0 mA adjustable)	Over range
	2mA (1.0 - 3.5 mA - adjustable)	Under range (Fault)
Alarm Relay 1*	Value is sensor dependant	Lower alarm level
	De-energized	Energizes on alarm
	Contact Normally Open (NO)	Closes on alarm
Alarm Relay 2*	Value is sensor dependant	Higher alarm level
	De-energized	Energizes on alarm
	Contact Normally Open (NO)	Closes on alarm
Fault Relay	Value is sensor dependant	Detector Fault
	Energized	De-energizes on alarm
	Contact Normally Closed (NC)	Opens on alarm
Password	1234	password to menu access

Table 24: PQ Series default Configuration

Detector Default Alarm Settings					
Gas Name	Range	Lower Alarm	Lower Alarm Type	Higher Alarm	Higher Alarm Type
Oxygen	25.0%vol	19%Vol	Falling	23%vol	Rising
Toxic	1-1000ppm	%10 of FS	Rising	%15 of FS	Rising
VOC	100-1000ppm	%10 of FS	Rising	%15 of FS	Rising
Refrigerant gases	2000-10000ppm	%10 of FS	Rising	%15 of FS	Rising
Flammable	100%LEL	10%LEL	Rising	15%LEL	Rising
Carbon Dioxide	5%Vol	1%Vol	Rising	2%Vol	Rising
	5000ppm	2000ppm	Rising	3000ppm	Rising

Table 25: PQ Series default alarm settings

Performance and Configuration Data:

PQ Series gas detector with the Pellistor sensor board (type PRS-K033) was tested according to the standards IEC EN 60079-29-1 for performance characteristics. PQ series Series gas detector with the Pellistor sensor board can be used to monitor different flammable gas types. Please contact to Prosense for the correct gas type cross factor settings.

Gas Name	Sensor	Default Range	Resolution	Accuracy (ppm or % of applied gas)	Calibration Gas	T90*(sec)
LPG	Pellistor	0-100%LEL	1%LEL	±3% FS or ±10%	25 to 75% of full range typically 30%LEL CH4	< 40
	Infrared	0-100%LEL	1%LEL	±3% FS or ±10%	25 to 75% of full range typically 30%LEL CH4	< 40
Methane	Pellistor	0-100%LEL	1%LEL	±3% FS or ±10%	25 to 75% of full range typically 30%LEL CH4	< 40
	Infrared	0-100%LEL	1%LEL	±3% FS or ±10%	25 to 75% of full range typically 30%LEL CH4	< 40
Petrol Vapours	Pellistor	0-100%LEL	1%LEL	±3% FS or ±10%	25 to 75% of full range typically 30%LEL CH4	< 40
	Infrared	0-100%LEL	1%LEL	±3% FS or ±10%	25 to 75% of full range typically 30%LEL CH4	< 40
n-Butane	Pellistor	0-100%LEL	1%LEL	±3% FS or ±10%	25 to 75% of full range typically 30%LEL CH4	< 40
	Infrared	0-100%LEL	1%LEL	±3% FS or ±10%	25 to 75% of full range typically 30%LEL CH4	< 40
Propane	Pellistor	0-100%LEL	1%LEL	±3% FS or ±10%	25 to 75% of full range typically 30%LEL CH4	< 40
	Infrared	0-100%LEL	1%LEL	±3% FS or ±10%	25 to 75% of full range typically 30%LEL CH4	< 40
Hexane	Pellistor	0-100%LEL	1%LEL	±3% FS or ±10%	25 to 75% of full range typically 30%LEL CH4	< 40
	Infrared	0-100%LEL	1%LEL	±3% FS or ±10%	25 to 75% of full range typically 30%LEL CH4	< 40
Hydrogen	Pellistor	0-100%LEL	1%LEL	±3% FS or ±10%	25 to 75% of full range typically 30%LEL CH4	< 40
	Electrochemical	0-2000ppm	10ppm	±10 or ±10%	50% of full range target gas	< 50
Pentane	Pellistor	0-100%LEL	1%LEL	±3% FS or ±10%	25 to 75% of full range typically 30%LEL CH4	< 40
	Infrared	0-100%LEL	1%LEL	±3% FS or ±10%	25 to 75% of full range typically 30%LEL CH4	< 40
Toluene	Pellistor	0-100%LEL	1%LEL	±3% FS or ±10%	25 to 75% of full range typically 30%LEL CH4	< 40
Methyl Alcohol	Pellistor	0-100%LEL	1%LEL	±3% FS or ±10%	25 to 75% of full range typically 30%LEL CH4	< 40
Heptane	Pellistor	0-100%LEL	1%LEL	±3% FS or ±10%	25 to 75% of full range typically 30%LEL CH4	< 40
Octane	Pellistor	0-100%LEL	1%LEL	±3% FS or ±10%	25 to 75% of full range typically 30%LEL CH4	< 40
Ethyl Alcohol	Pellistor	0-100%LEL	1%LEL	±3% FS or ±10%	25 to 75% of full range typically 30%LEL CH4	< 40

Gas Name	Sensor	Default Range	Resolution	Accuracy (ppm or % of applied gas)	Calibration Gas	T90*(sec)
Iso Propanol	Pellistor	0-100%LEL	1%LEL	±3% FS or ±10%	25 to 75% of full range typically 30%LEL CH4	< 40
Carbon monoxide	Electrochemical	0-300ppm	1ppm	±1 or ±10%	50% of full range target gas	< 40
	Electrochemical	0-500ppm	1ppm	±1 or ±10%	50% of full range target gas	< 45
	Electrochemical	0-1000ppm	10ppm	±10 or ±10%	50% of full range target gas	< 45
	Pellistor	0-100%LEL	1%LEL	±3% FS or ±10%	25 to 75% of full range typically 30%LEL CH4	< 40
Acetone	Pellistor	0-100%LEL	1%LEL	±3% FS or ±10%	25 to 75% of full range typically 30%LEL CH4	< 40
Methyl Ethyl Ketone	Pellistor	0-100%LEL	1%LEL	±3% FS or ±10%	25 to 75% of full range typically 30%LEL CH4	< 40
Ethyl Acetate	Pellistor	0-100%LEL	1%LEL	±3% FS or ±10%	25 to 75% of full range typically 30%LEL CH4	< 40
Ammonia	Electrochemical	0-100ppm	1ppm	±3% FS or ±10%	25 to 75% of full range typically 30%LEL CH4	< 45
	Electrochemical	0-1000ppm	1ppm	±3% FS or ±10%	25 to 75% of full range typically 30%LEL CH4	< 45
	Pellistor	0-100%LEL	1%LEL	±3% FS or ±10%	25 to 75% of full range typically 30%LEL CH4	< 40
Ethylene	Pellistor	0-100%LEL	1%LEL	±3% FS or ±10%	25 to 75% of full range typically 30%LEL CH4	< 40
Acetic Acid	Pellistor	0-100%LEL	1%LEL	±3% FS or ±10%	25 to 75% of full range typically 30%LEL CH4	< 40
Butyl Acetate	Pellistor	0-100%LEL	1%LEL	±3% FS or ±10%	25 to 75% of full range typically 30%LEL CH4	< 40
Cyclo Hexane	Pellistor	0-100%LEL	1%LEL	±3% FS or ±10%	25 to 75% of full range typically 30%LEL CH4	< 40
Cyclo Pentane	Pellistor	0-100%LEL	1%LEL	±3% FS or ±10%	25 to 75% of full range typically 30%LEL CH4	< 40
Dioxane	Pellistor	0-100%LEL	1%LEL	±3% FS or ±10%	25 to 75% of full range typically 30%LEL CH4	< 40
Ethane	Pellistor	0-100%LEL	1%LEL	±3% FS or ±10%	25 to 75% of full range typically 30%LEL CH4	< 40
Butyl Alcohol	Pellistor	0-100%LEL	1%LEL	±3% FS or ±10%	25 to 75% of full range typically 30%LEL CH4	< 40
Styrene	Pellistor	0-100%LEL	1%LEL	±3% FS or ±10%	25 to 75% of full range typically 30%LEL CH4	< 40
Propylene	Pellistor	0-100%LEL	1%LEL	±3% FS or ±10%	25 to 75% of full range typically 30%LEL CH4	< 40
Xylene	Pellistor	0-100%LEL	1%LEL	±3% FS or ±10%	25 to 75% of full range typically 30%LEL CH4	< 40
Acetylene	Pellistor	0-100%LEL	1%LEL	±3% FS or ±10%	25 to 75% of full range typically 30%LEL CH4	< 40
Benzene	Pellistor	0-100%LEL	1%LEL	±3% FS or ±10%	25 to 75% of full range typically 30%LEL CH4	< 40
Ethylene Oxide	Electrochemical	0-20ppm	0.2 ppm	±0.2 or ±10%	50% of full range target gas	< 150
Vinyl Acetate	Pellistor	0-100%LEL	1%LEL	±3% FS or ±10%	25 to 75% of full range typically 30%LEL CH4	< 40

Gas Name	Sensor	Default Range	Resolution	Accuracy (ppm or % of applied gas)	Calibration Gas	T90*(sec)
Hydrogen Sulfide	Electrochemical	0-100ppm	1ppm	±1 or ±10%	50% of full range target gas	< 40
	Electrochemical	0-500ppm	1ppm	±1 or ±10%	50% of full range target gas	< 40
Oxygen	Electrochemical	0-25%VOL	0.1%vol	±0.1% O2	18%vol O2	< 25
Sulphur Dioxide	Electrochemical	0-10ppm	0.1ppm	±0.1 or ±10%	50% of full range target gas	< 40
Nitric Oxide	Electrochemical	0-250ppm	1ppm	±0.1 or ±10%	50% of full range target gas	< 45
Nitrogen Dioxide	Electrochemical	0-30ppm	0.3ppm	±0.3 or ±10%	50% of full range target gas	< 30
Chlorine	Electrochemical	0-10ppm	0.1ppm	±0.1 or ±10%	50% of full range target gas	< 65
Hydrocarbon	Pellistor	0-100%LEL	1%LEL	±3% FS or ±10%	25 to 75% of full range typically 30%LEL CH4	< 40
	Infrared	0-100%LEL	1%LEL	±3% FS or ±10%	25 to 75% of full range typically 30%LEL CH4	< 40
Carbon Dioxide	Infrared	0-5000ppm	5ppm	±10 or ±10%	2000ppm CO2	< 40
	Infrared	0-5%VOL	0.1%vol	±0.01% CO2	2%vol CO2	< 40
Freon	Semiconductor	0-2000ppm	10ppm	±10 or ±10%	50% of full range target gas	< 65
JP8 Fuel	Pellistor	0-100%LEL	1%LEL	±3% FS or ±10%	25 to 75% of full range typically 30%LEL CH4	< 30
Formaldehyde	Electrochemical	0-10ppm	0.1ppm	±0.1 or ±10%	50% of full range target gas	< 120
	Pellistor	0-100%LEL	1%LEL	±3% FS or ±10%	25 to 75% of full range typically 30%LEL CH4	< 30
Hydrogen Cyanide	Electrochemical	0-25ppm	0.1ppm	±0.1 or ±10%	15ppm HCN	< 75
Hydrogen Peroxide	Electrochemical	0-5000ppm	10ppm	±10 or ±25%	50% of full range target gas	< 40
Nonane	Pellistor	0-100%LEL	1%LEL	±3% FS or ±10%	25 to 75% of full range typically 30%LEL CH4	< 30
Acetaldehyde	Pellistor	0-100%LEL	1%LEL	±3% FS or ±10%	25 to 75% of full range typically 30%LEL CH4	< 30
Hydrogen Chloride	Electrochemical	0-30ppm	1ppm	±0.1 or ±10%	50% of full range target gas	< 300
TVOC	Electrochemical	0-100ppm	1ppm	±1 or ±10%	25ppm Isobutylene	< 65
		0-1000ppm	10ppm	±10 or ±10%	100ppm Isobutylene	< 65
VOC	PID	0-100ppm	1ppm	±1 or ±10%	25ppm Isobutylene	< 10
		0-1000ppm	1ppm	±10 or ±10%	100ppm Isobutylene	< 10
Ozone	Electrochemical	0-1ppm	0.01ppm	±0.1 or ±20%	50% of full range target gas	< 90
Hydrofluoric Acid(HF)	Electrochemical	0-10ppm	0.1ppm	±0.1 or ±10%	50% of full range target gas	< 65
Phosphine	Electrochemical	0-10ppm	0.1ppm	±0.1 or ±10%	50% of full range target gas	< 30
Isobutylene	Pellistor	0-100%LEL	1%LEL	±3% FS or ±10%	25 to 75% of full range typically 30%LEL CH4	< 30

Table 26: PQ Series performance and calibration data

NOTES

Performance figures are taken at 20~25C;

1. measured using a sample humidity of 50%RH, applicable between 10 and 90% of full scale,
2. measured using test units calibrated at 50% of full scale,
3. measured at 0,5lt/min for gas flow.

Response time (T90) may increase when operating in lower temperature conditions or when gas is introduced with the additional IP66 adapter fitted.

Data represents typical values, and system conditioning may be required to achieve stated result. Contact Prosense for details.

SAFETY INSTRUCTIONS FOR HAZARDOUS AREA INSTALLATION

Prosense PQ series gas detectors are projected and built according to ATEX Directive 2014/34/EU with reference to standard IEC EN 60079-0, IEC EN 60079-1, IEC EN 60079-30, IEC EN 60079-29-1. "ATEX", by the French "ATmosphere EXplosible", provides the technical requirements to be applied to equipment intended for use in potentially explosive atmospheres. The Prosense PQ series gas detectors must be installed and maintenance according to the suitable standards for electrical application in potentially explosive atmospheres (example: EN 60079-14, EN 60079-17 or other national standards).

Read this instruction first and keep this instruction manual always available.

The following instructions apply to equipment covered by ATEX/IECEx/UKEX/UL certificate number:

1- PQ Series gas detectors for monitoring a very wide range of toxic and flammable gases and oxygen. PQ series are available as Flameproof (Ex db/tb) detectors suitable for use in Zone 1/2 and Zone 21/22 hazardous areas.

Device category 2GD, Identification II 2GD

Ex db IIC T6 Gb (Tamb = -40 °C ÷ +70 °C) – For explosion protection

(Tamb = -20 °C ÷ +60 °C) – For performance requirements

Ex tb IIIC T85°C Db

It means:  (European Community logo for ATEX applications) – group II (potentially explosive atmospheres – surface application – OTHER than mines)

Category 2GD (G => Gas D=>Dust) – Zone 1 and Zone 2 /Zone 21 and Zone 22

Ex db => protection mode: explosion proof enclosure

IIC => define kind of gases

T6 => Temperature class -- Maximum allowable surface temperature.

IP 65 => Mechanical protection degree – protection against solid, dust and liquid.

2. Suitably trained personnel shall carry out installation in accordance with applicable code practice.

3. The electrical devices must be grounded using their grounding connections. The grounding connection must be ATEX/IECEx/UKEX/UL certified, suitable for the application required, substances, maximum superficial temperature, and ambient temperature.

4. The user should guarantee periodical cleaning of the places where dust can store to avoid the piling up to 5 mm.

5. The user should not repair this equipment.

6. The user should guarantee the keeping of the safety characteristic of the device after maintenance or repairing.

7. If the equipment is likely to come into contact with aggressive substances, it is responsibility of the user to take suitable precautions that prevent it from being adversely affected, thus ensuring that the type of protection is not compromised.

Aggressive substances: example Acids, liquid, gases with can affected metals

8. To guarantee the respect of the protection degree cable glands, blanking elements and thread adapters shall be certified Ex components according to protection “db” and a blanking element shall not be used with an adapter.
9. Sinter replacement shall be done by an approved technical service personal according to PQ Series user manual “Sinter replacement” procedure.
10. O-ring is made of Silicone and continuous operating temperature is -50C to 105C
11. If temperature exceeds 70°C at entry or 80°C at branching point use suitably rated cable and cable glands or conductors in conduit.
12. Thickness of outer painting is between 40 µm – 180 µm.
13. Maximum power consumption of the detector with optional boards installed is $P_{max}=4W$ where $I_{max}=335mA$ and $V_{max}=24VDC$.
14. All electrical connections should be made in accordance with any relevant local or national legislation, standards or codes of practice. Prosense detectors can operate between 12 - 24 VDC. The connection, grounding, cabling details are explained in this guide at relevant sections
15. It is recommended to use industrial grade and suitably shielded cable.
16. Good grounding is essential to ensure good EMC and RFI immunity
17. Flamepaths must not be repaired.
18. When the painted enclosure is intended for use in Group III applications, the end user must adhere to the manufacturer’s instructions to minimise risk of electrostatic discharge
19. PQ Series gas detectors must be installed only with sensor head pointing downwards.
20. Cable glands and thread adapters used for entry into the enclosure, as well as blanking elements, shall be certified as Ex Components according to protection “d”, and suitable for the ambient temperature range specified in introduction section.
21. Do not remove or replace the battery

Declaration



EU Declaration of Conformity

Prosense Teknoloji San Ltd. Şti declares the PQ series products to be in accordance with the following standards and directives.

Name and address of Manufacturer: **Prosense Teknoloji San Ltd Şti**
Cumhuriyet Mah. Mermer Sok No:16
34876 - Kartal – İstanbul – Türkiye

Description of Device: PQ Series Fixed Type Gas Detector

Ex Designation:  II 2 G Ex db IIC T6 Gb
 II 2 D Ex tb IIIC T85°C Db

Applied Harmonized international standards:

EN/IEC 60079-0:2018 Equipment – General requirements
EN/IEC 60079-1:2014 Equipment protection by flameproof enclosures ‘d’
EN/IEC 60079-31:2014 Explosive atmospheres Part 31: Equipment dust ignition protection by enclosure ‘t’
EN/IEC 60079-29-1:2016 Gas detectors – Performance requirements of detectors for flammable gases
EN/IEC 50270:2015 Electromagnetic compatibility - Electrical apparatus for the detection and measurement of combustible gases, toxic gases and oxygen
EN/IEC 50271:2018 Electrical apparatus for the detection and measurement of combustible gases, toxic gases or oxygen - Requirements and tests for apparatus using software and/or digital technologie

Applied European Directives:

2014/34/EU ATEX Directive
2014/30/EU Electromagnetic Compatibility (EMC) Directive

Each PQ Series gas detector device which the Production Quality Assurance procedures and Type Examination procedures have been applied has been shown to conform to an approved Type and to the applicable classification rules and essential principles before being supplied. This declaration is being made on the basis of the following certificates:

<i>Quality Management Certificate:</i>	18ISO0073
<i>Production Quality Assurance Certificate:</i>	ExVeritas 18PQAN0072
<i>ATEX Type Examination Certificate:</i>	UL 21 ATEX 2656X
<i>IECEX Certificate of Conformity:</i>	IECEX ULD 21.0033X
<i>Performance approval (EN/IEC 60079-29-1):</i>	FTZU 18 ATEX 0086

Authorised Signatory: **Firat Celep**
Production Manager

Date: **12.10.2022**

UK Declaration of Conformity



Prosense Teknoloji San Ltd. Şti declares the PQ series products to be in accordance with the following standards and directives.

Name and address of Manufacturer: **Prosense Teknoloji San Ltd Şti**
Cumhuriyet Mah. Mermer Sok No:16
34876 - Kartal – İstanbul – Türkiye

Description of Device: PQ Series Fixed Type Gas Detector

Ex Designation:  II 2 G Ex db IIC T6 Gb
 II 2 D Ex tb IIC T85°C Db

Applied Harmonized international standards:

EN/IEC 60079-0:2018 Equipment – General requirements
EN/IEC 60079-1:2014 Equipment protection by flameproof enclosures 'd'
EN/IEC 60079-31:2014 Explosive atmospheres Part 31: Equipment dust ignition protection by enclosure "t"
EN/IEC 60079-29-1:2016 Gas detectors – Performance requirements of detectors for flammable gases
EN/IEC 50270:2015 Electromagnetic compatibility - Electrical apparatus for the detection and measurement of combustible gases, toxic gases and oxygen
EN/IEC 50271:2018 Electrical apparatus for the detection and measurement of combustible gases, toxic gases or oxygen - Requirements and tests for apparatus using software and/or digital technologie

Applied European Directives:

2014/34/EU ATEX Directive
2014/30/EU Electromagnetic Compatibility (EMC) Directive

Each PQ Series gas detector device which the Production Quality Assurance procedures and Type Examination procedures have been applied has been shown to conform to an approved Type and to the applicable classification rules and essential principles before being supplied. This declaration is being made on the basis of the following certificates:

<i>Quality Management Certificate:</i>	18ISO0073
<i>Production Quality Assurance Certificate:</i>	ExVeritas 18PQAN0072
<i>UKEX Type Examination Certificate:</i>	UL22UKEX2376X
<i>IECEX Certificate of Conformity:</i>	IECEX ULD 21.0033X
<i>Performance approval (EN/IEC 60079-29-1):</i>	FTZU 18 ATEX 0086

Authorised Signatory: **Firat Celep**
Production Manager

Date: **12.10.2022**

Warranty statement

All products are designed and manufactured to the latest internationally recognized standards by Prosense under a Quality Management system that is ISO 9001 certified. As such Prosense warrants its products against defective parts and workmanship and will repair or (at its option) replace any instruments which are or may become defective under proper use within 12 months from date of shipment from Prosense Technology. The Product will be returned repaired or replaced if it is determined by Prosense that the part failed due to defective materials or workmanship. Warrant is only valid if product is shipped prepaid to Prosense at Kartal, Istanbul TURKEY, in a package equal to or in the original container accompanied by a detailed description of any issue. Prosense reserves the right to charge for any site attendance where any fault is not found with the equipment in case return of goods is not practicable. Prosense shall not be liable for any loss or damage whatsoever or howsoever occasioned which may be a direct or indirect result of the use or operation of the Contract Goods by the Buyer or any Party.

This warranty covers instrument and parts sold to the Buyer only by authorized distributors, dealers and representatives as appointed by Prosense Technology. The warranties set out in this clause are not pro rata, i.e. the initial warranty period is not extended by virtue of any works carried out there under.

Exclusions

If gas sensors are part of the Product, the gas sensor is covered by a twelve (12) month limited warranty of the manufacturer. The gas sensors are covered by this limited warranty is subject to inspection by Prosense for extended exposure to excessive gas concentrations if a claim by the user is made under this limited warranty. Should such inspection indicate that the gas sensor has been expended rather than failed prematurely, this limited warranty shall not apply to the Product.

This limited warranty does not cover consumable items, such as batteries, or items subject to wear or periodic replacement, including lamps, fuses, valves, vanes, sensor elements, cartridges, sinters or filter elements. This warranty does not cover damage caused by accident, abuse, abnormal operating conditions or poisoning of sensor.

Warranty Limitation and Exclusion

Prosense will have no further obligation under this limited warranty. All warranty obligations of Prosense are void in below cases:

- if the Product has been subject to abuse, misuse, negligence, or accident
- if the Distributor or User fails to perform any of the duties set forth in this limited warranty
- if the Product has not been operated in accordance with instructions
- if the Product serial number has been removed or altered

Limitation of Liability

In no event will Prosense Technology be liable for any incidental damages, consequential damages, special damages, punitive damages, statutory damages, indirect damages, loss of profits, loss of revenues, or loss of use, even if informed of the possibility of such damages.

It is understood and agreed that Prosense' liability, whether in contract, in tort, under any warranty, in negligence or otherwise shall not exceed the amount of the purchase price paid by the purchaser for the product. Under no circumstances shall Prosense be liable for special, indirect, or consequential damages. The price stated for the product is a consideration limiting Prosense' liability. No action, regardless of form, arising out of the transactions under this warranty may be brought by the purchaser more than one year after the cause of actions has occurred. To the extent permitted by applicable law, these limitations and exclusions will apply regardless of whether liability arises from breach of contract, warranty, tort (including but not limited to negligence), by operation of law, or otherwise.

Please contact info@prosense.com.tr for any inquiry or complaints.

